

## ROTAN PUMP

Types GP, HD, PD, CD, MD, CC

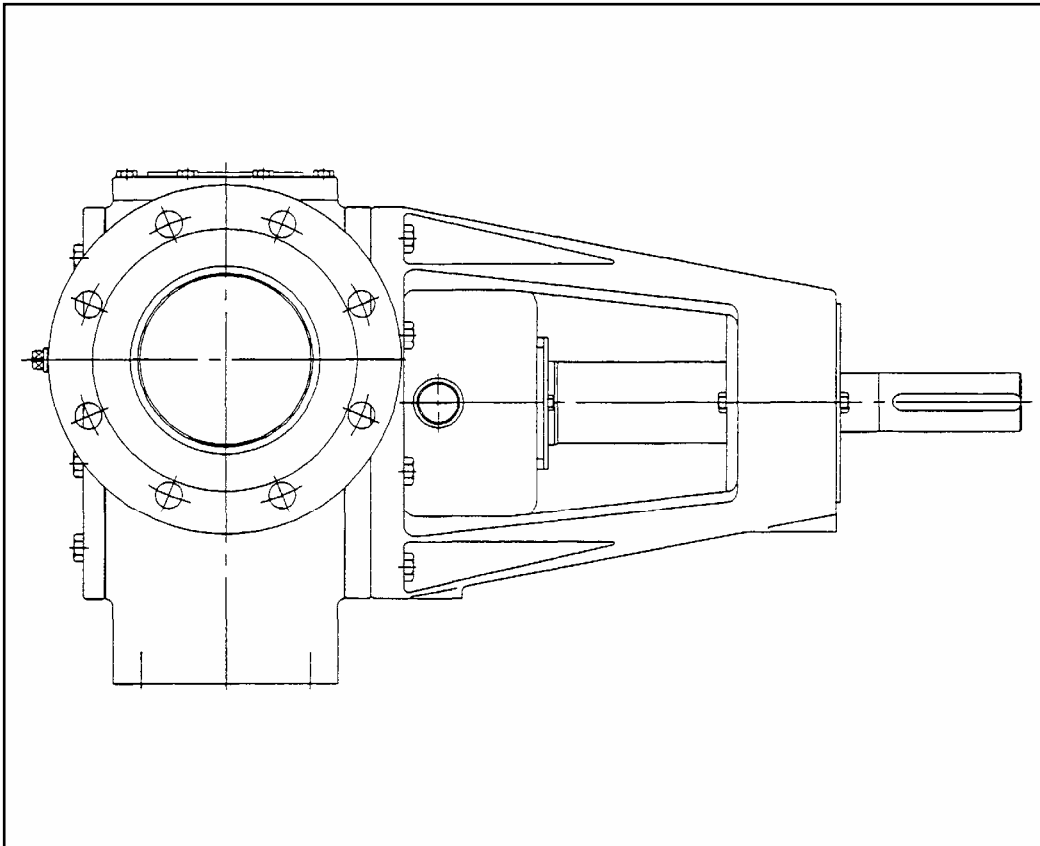

**DESMI INC** – Member of the DESMI Group  
2551 Eltham Ave, Suite G, Norfolk, VA 23513, USA  
Tel.: +1 757 857 7041  
Fax: +1 757 857 6989  
E-mail: [info@desmiusa.com](mailto:info@desmiusa.com)  
Internet: [www.desmiusa.com](http://www.desmiusa.com)

Manual: T1456USA

# EC Declaration

This document contains two declarations, only one of which is valid for the pump supplied.

**The EC Component Declaration** is valid for pumps supplied **without** a motor, which makes the EC declaration of conformity invalid.

**The EC Declaration of Conformity** is valid for pumps supplied **with** a motor, which makes the EC component declaration invalid. The pump is also declared **only** in accordance with the ATEX Directive in the event that the pump has been ordered for use in a potentially explosive environment, as ROTAN pumps as a rule are **not** supplied in accordance with the ATEX Directive.

The information on the pump's nameplate will define whether it can be used in a potentially explosive environment.

**Manufacturer:** DESMI A/S  
**Address:** Tagholm 1. Postboks 226. DK-9400 Nørresundby. Denmark.  
**Tel.:** +00 45 96 32 81 11  
**E-mail:** [desmi@desmi.com](mailto:desmi@desmi.com)



**Product:** ROTAN pumps  
**Type:** HD, CD, PD, GP, CC, MD and RT

## EC directives:

98/37/EC The Machine Directive  
89/336/EEC The EMC Directive  
73/23/EEC The Low Voltage Directive (**only** applies for pumps supplied with a motor)

94/9/EC The ATEX Directive (**only** applies for pumps ordered for use in a potentially explosive environment  
**EEx II 2GD c** **and** where this is stated on the pump's name plate)  
The ATEX documentation is registered by the authorized institution: Physikalisch- Technische Bundesanstalt PTB. Postfach 33 45. 38023 Braunschweig – **PTB registration number 03ATEX D052**

## Harmonized standards/other standards:

DS/EN 292-1/2 Machine safety  
Basic concepts, general principles for planning, construction and design.  
DS/EN 294 Machine safety. Hazardous areas and safety distances. Protection of hands and arms.  
DS/EN 809 Joint safety requirements – Pumps and pump units for liquids  
DS/EN 12162 Liquid pumps – Safety requirements – Procedure for hydrostatic testing  
DS/EN 13463-1 Non-electric equipment for use in explosive atmospheres. - Part 1: Basic methods and requirements.  
PrEN 13463-5 Non-electrical equipment intended for use in potentially explosive atmospheres.  
Part 5: Protection by constructional safety.  
DS/EN 1127-1 Machine safety. Explosive atmospheres. Prevention of and protection against explosion.  
Part 1: Basic concepts and methodology,  
(DS/EN 13463-1 + prEn 13463-5 + DS/EN 1127-1 are **only** observed by ATEX pumps).

## EC Component Declaration

(valid for ROTAN pumps supplied **without** a motor)

**Machine Directive 98/37/EC – Implementing Order no. 561, Annex II, B**

The above manufacturer hereby declares that the product in question has been produced in accordance with the specified EU directives and the national legislation that enforces them. The product is designed for use when connected to a motor, with the aim of creating a joint machine, and for this reason it does not – as a component – satisfy the provisions of these directives in all respects.

It is also declared that the harmonized standards specified, which implement these directives or parts of them, are satisfied.

When the pump is connected to a motor and thus – treated as one unit – constitutes a machine, this machine as a whole must be risk-assessed and declared in accordance with all the relevant provisions. These relevant provisions must also include the Machine Directive, as referred to in this declaration, and the ATEX Directive, if it is intended to set up the pump in a potentially explosive atmosphere.

It is declared that the product may not be taken into use until such compliance has taken place.

## EC Declaration of Conformity

(valid for ROTAN pumps supplied **with** a motor)

**Machine Directive 98/37/EC – Implementing Order no. 561, Annex II, A**

The above manufacturer hereby declares that the product in question has been produced in accordance with the specified EU directives and the national legislation that enforces them.

It is also declared that the harmonized standards specified, which implement these directives or parts of them, are satisfied.



Nørresundby, April 2004

Peter Hartig  
Technical Director

**DESMI A/S - Denmark**

**Name plate**

ROTAN® PUMP			
SX Valve		NO SEAL	
<b>DESMI INC.</b> 2551 Eltham Ave. Norfolk, Virginia			
<b>MADE IN DENMARK</b>			

This user manual is valid for any pump which contains the same nameplate information as is displayed above.

If the pump's and the motor's name plate bears an "EEx", the unit is suitable for use in a potentially explosive environment.



The name plate must never be removed from the pump.

If the name plate is removed, it is not possible to identify the pump, and it will not be possible for warnings contained in this manual to relate to the specific pump application.

The pump's order number and serial number are displayed on the flange.

This user manual has been produced in accordance with the directions of the Machine Directive 98/37/EC and the directions of standards DS/EN 62079, DS/EN 292-2 and DS/EN 809.

This user manual was last revised: 11.2004 – LDM - version 1A.

**Contents**

Name plate.....	1
1. General information.....	5
2. EC declaration of conformity .....	11
3. Safety .....	12
4. Safety – ATEX.....	13
5. About ROTAN .....	14
5.1. Pump models .....	14
6. ROTAN pump configuration options .....	16
7. Transporting the pump.....	17
8. Lifting the pump .....	17
9. Storage, long-term preservation and frost protection of the pump.....	20
9.1. Storage.....	20
9.2. Preservation procedure.....	21
9.3. Frost protection .....	21
10. Installation .....	21
10.1. Selecting the motor .....	22
10.2. Connecting the motor and the pump .....	22
10.2.1 Aligning the motor and the pump .....	23
10.3. Axial clearance.....	23
10.4. Horizontal/vertical positioning of the pump.....	24
10.4.1 Horizontal positioning of the pump .....	24
10.4.2 Vertical positioning of the pump.....	24
10.5. Positioning of the pump on the foundation .....	25
10.6. Before connecting the pipes.....	26
10.6.1 External loads on pump flanges .....	26
10.6.2 Flange coupling .....	28
10.6.3 Threaded coupling .....	29
10.7. By-pass valve .....	29
10.8. Temperature sensor .....	29
10.9. Emergency stop .....	30
10.10. Electrical coupling .....	30
10.11. Monitoring .....	30
11. Before starting the pump.....	31

11.1. Before starting after preservation .....	31
12. After starting the pump.....	32
12.1 Running in the soft shaft seal – when starting the pump .....	33
13. By-pass valve .....	33
13.1. Valve configurations.....	36
13.2. Positioning the valve .....	36
13.3. Operating principle – valve .....	37
13.4. Setting the by-pass valve.....	37
14. Pump liquids.....	42
14.1. Hot liquids .....	42
14.2. Foods .....	43
15. Noise .....	44
16. Storing the user manual .....	45
17. Maintenance .....	45
17.1. Adjusting the soft shaft seal.....	47
17.1.1. Repacking – soft shaft seal .....	48
17.2. Ball bearings .....	49
17.2.1 Lubricating ball bearings.....	49
17.2.2 Service life – ball bearings .....	51
17.3. Lubricating slide bearings .....	53
18. Troubleshooting.....	56
19. Emptying and cleaning the pump.....	57
20. Removal of liquid .....	58
Repairs.....	59
21.1. Setting of temperature sensor.....	59
21.2. Axial clearance.....	60
21.1.1 Checking the axial clearance.....	60
21.1.2 Setting the axial clearance.....	61
22. Spare parts .....	66
23. Ordering spare parts.....	66
23.1. Spare parts drawings .....	66
24. Spare parts list .....	71
25. Technical specifications.....	73

25.1. Capacity .....	73
25.2. Speed .....	73
25.3. Operating pressure .....	74
25.4. Suction lift .....	74
25.5. Viscosity .....	75
25.6. Temperature .....	75
26. Supplementary requirements for ATEX pumps .....	76
26.1. Reservations .....	76
27. The maintenance process .....	77
27.1. The service life of ball bearings .....	77
27.2. Inspection .....	77
28. The DESMI Group .....	79

## 1. General information

This user manual relates to ROTAN internal gear pumps.

The entire user manual must be read thoroughly before the pump is transported, lifted, installed, assembled, or any other activity described in this user manual. Everyone who is to work with the pump must read this user manual before it is put into operation.

Upon receipt, check that the delivery is complete and undamaged. Any deficiencies or damage must be reported immediately to the transport company and the supplier, in order to validate a claim.

The user is responsible for compliance with the safety requirements described in this user manual.

If the person who is expected to refer to the user manual is of different linguistic origin than the language in which the user manual has been supplied, it is recommended that the user manual be translated into the language in question.

In addition to the instructions contained in this user manual, also refer to the prevailing local national laws and regulations. The user is responsible for compliance with these laws.

The owner of the pump is responsible for ensuring that everyone who works with the pump has the necessary background.

In the event that this user manual or other regulations recommend the use of personal protective equipment or limitations on the use of labor and the pump, such instructions must be observed.

The owner or user of the pump must ensure that this manual is updated if there are any modifications to the pump.

In the event that the pump is transferred to a third party, this user manual and the operating conditions defined when the order was submitted *must* accompany the pump.

The pump may only be used under the operating conditions specified when the order was placed. Any deviation from this requires DESMI's consent.

DESMI assumes no liability for any personal injury or damage to the pump resulting from:

- a failure to observe the safety regulations or other instructions in this user manual
- the use of non-original spare parts that do not satisfy the same strict quality requirements as original DESMI spare parts
- any fault, blockage or breakdown in the pipe system

The owner or user is responsible for protecting the pipe system against faults, blockages and explosions.

**Quality management system:**

ROTAN pumps are manufactured in accordance with DESMI's quality management system, which is certified by BVQI in accordance with the requirements of ISO 9001.

**Testing of pumps:**

All ROTAN pumps and by-pass valves have been *statically* and *dynamically* tested in the factory.

Static pressure testing is conducted to ensure that the pumps do not leak, and that they can maintain the specified maximum operating pressure.

The dynamic test is conducted to ensure that the pump can deliver the specified volume of liquid at the specified pressures.

The pumps are tested with oil.

However, pumps for liquids used in the food industry are tested exclusively with vegetable oil. Pumps fitted with a heating jacket/cooling jacket are also specially tested to achieve extra safety to ensure that the heating liquid in the front cover and the cooling jacket on the rear cover cannot pass into the pump liquid.

All pumps are delivered with a signed test certificate.

The tests described are conducted in accordance with the procedures set out in DESMI's quality management system and in accordance with international classification companies.

This user guide covers all standard versions of the ROTAN pump.  
It applies to pump types described in Figure  
pump sizes described in Figure

pump versions described in the section entitled “Pump models”, and the versions shown in Figure

In this manual the front and the rear ends of the ROTAN pump are referred to. Figure shows which end is called front and which is called rear.

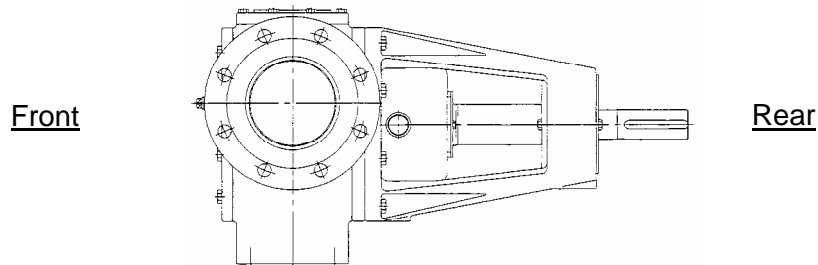

Figure 1: Front and rear of the ROTAN pump.

The ROTAN pump has a modular construction, and can be supplied in a number of options. Because of the large number of possible combinations, it is not possible to cover all models or special versions available in this user manual. If the user manual proves to be incomplete with regard to the above or to the item supplied, you are of course welcome to contact DESMI.

This user manual differentiates between the terms:

- pump types
- pump sizes
- pump models
- pump versions

### **Pump types:**

The Rotan pump is supplied in the following pump types:

Pump types – application		
Pump type:	Designation	Application:
GP	General Purpose	Mainly pumping of clean oils
HD	Heavy Duty	Mainly pumping of highly viscous liquids <u>Typical applications:</u> oils, asphalt, chocolate, paint, lacquer, molasses, soap and similar liquids <u>Used for processes in:</u> process industry
PD	Petrochemical Duty	<u>Typical applications:</u> lubricating oil, petrol, lubricants and other hydrocarbons. <u>Used for processes in:</u> refineries and the petrochemical industry
CD	Chemical Duty	To pump corrosive liquids <u>Typical applications:</u> organic acids, fatty acids, alkalis, caustic soda, polymer solutions, soap, shampoo, animal fat, vegetable fat, chocolate and other special liquids <u>Used for processes in:</u> chemical industry, food industry and the cosmetic industry
MD	Magnetic Drive	Used to pump all the above liquids MD pumps are particularly environment-friendly, and provide a 100% guarantee against liquid or air leakage.
CC	Closed Coupled	Particularly for pumping oil products <u>Used for processes in:</u> engineering industry

Figure2: A list of the various pump types, their designation and application.

### **Pump sizes:**

The ROTAN pump is supplied in various pump sizes.  
The pump size is defined on the basis of the pump's inlet/outlet.

By measuring the internal diameter of the pump's inlet/outlet, you can find the pump size in the table below.

Pump sizes		
Pump sizes	Nominal diameter in mm	Internal diameter in inches
26	25	1"
33	32	1 1/4"
41	40	1 1/2"
51	50	2"
66	65	2 1/2"
81	80	3"
101	100	4"
126	125	5"
151*	150	6"
152*	150	6"
201	200	8"

Figure 3: A list of pump sizes based on the internal diameter of the pump's inlet/outlet in inches and millimeters. \*Pump sizes 151 and 152 are pumps of two different sizes, but with the same size inlet/outlet.

The various pump types are available in the pump sizes listed in Figure

Pump types/sizes						
Pump size	Pump types					
	GP	HD	PD	CD	MD	CC
26						
33						
41						
51						
66						
81						
101						
126						
151						
152						
201						

Figure 4: A list of the various pump sizes together with the pump types available in the various pump sizes. Fields that are shaded grey indicate the sizes available in the pump types listed.

The pump's inlet/outlet can be supplied with internal threads or flanges. All pump types and pump sizes can be supplied with flanges to match connecting objects. The pump is supplied with an internal thread in the pump types and pump sizes listed in Figure 5.

Pump size	Pumps tapped for standard pipes						
	GP	HD	PD	Pump types		MD	CC
				CD	stainless		
26							
33							
41							
51							
66							
81							
101							
126							
151							
152							
201							

Figure 5: A list of the various pump sizes and pump types tapped for standard pipes. Fields that are shaded grey indicate the pump types and pump sizes supplier with an internal thread.

### Heating/cooling jackets:

Rotan pumps can be fitted with a heating jacket or a cooling jacket on the front cover and/or the rear cover. Heating jackets are used to keep the pump liquid fluid, and are often necessary when pumping highly viscous liquids or liquids that tend to coagulate. The heating jacket on the rear cover can also be used to heat liquid-lubricated shaft seals.

The jacket can also be used as a cooling jacket for the shaft seal on the rear cover or a cooling jacket to cool the pump liquid on the front cover.

We recommend that the pump be heated before operation.

The heating/cooling chambers are heated or cooled by connecting a separate circulatory system that circulates heating liquids such as water, steam or oil.



The pressure in the heating chamber on the front cover and the cooling chamber on the rear cover may not exceed 10 bar/145 psi.



The liquid in the heating chambers must have an ignition temperature of at least 50°C/122°F above the pump's maximum surface temperature.



## 2. EC declaration of conformity

ROTAN pumps are CE-labeled from the factory and supplied with an EC declaration of conformity or an EC component declaration – depending on whether the pump has been bought with or without a motor.

When fitting a ROTAN pump in an existing system and connecting the pumps to motors, we would point out that the whole plant/combination of motor and pump must be assessed and given a new CE label in order to ensure that the combination represents no new health and safety hazards.



Please note that pumps supplied by DESMI without a motor must be connected using an explosion-proof motor if you intend to use the pump in a potentially explosive atmosphere.

A ROTAN pump may not be put into operation until this CE labeling procedure has taken place. The manufacturer that ultimately assembles the final system is responsible for ensuring that such compliance is achieved.

DESMI is not responsible for this compliance.

The above requirement is valid within the EC.

### 3. Safety



All work on the pump – including adjustments, repairs, pipe couplings, etc. – must be undertaken by professionally qualified staff.



When repair and maintenance work has been completed, any safety equipment provided must be refitted in its original state before the pump is started.



Never shut off the pump's suction and/or pressure side during operation.



If it is possible to block the pump's pressure line, the pump or pressure line must be fitted with a by-pass valve.



Motors fitted with lifting eyes must not be used to lift the whole pump, only to lift the motor separately.



The pump must be lifted in accordance with the instructions contained in this user manual – see section entitled “Lifting the pump”.



If the pump's weight is over the permitted allowance of kilos/pounds that people may lift, it must be lifted mechanically – see section entitled “Lifting the pump”.



It is forbidden to remain in the pump's working area without cause during operation.



Emergency exits in the pump's work location must not be blocked.



The emergency stop must be positioned in close proximity to the pump – see section entitled “Emergency stop”!



The pump must be shielded when pumping liquids at high temperatures – see section entitled “Pump liquids”!  
Warning signs must be displayed!



The pump must not be used to pump liquids at temperatures above those listed in the table under “Hot liquids” – see section entitled “Hot liquids”!



Protective shields must not be removed when the pump is in operation.



Protective gloves must be used when adjusting axial clearance, if liquids at high or low temperatures are being pumped.



The soft shaft seal must not be adjusted when the pump is in operation.



The ROTAN pump must not be used to pump foods requiring FDA or 3A approval – see section entitled “Pump liquids”.



Use hearing protection when close to the pump, when the noise level exceeds the maximum permitted values – see section entitled “Noise”.  
If necessary, display a sign stating that hearing protection must be worn!



Electrical couplings must be established by authorized professionals, in accordance with the prevailing standards and directives.

#### 4. Safety – ATEX



Pumps must not be used in a potentially explosive environment, unless the pump’s name plate is labeled EEx II 2GD c – see the pump’s name plate!

## 5. About ROTAN

### 5.1. Pump models

The ROTAN pump has a modular construction, and can be supplied in a large number of models. The pump's nomenclature is made up of a series of codes, which describe various features of the pump.

Below is an example of some of the codes.

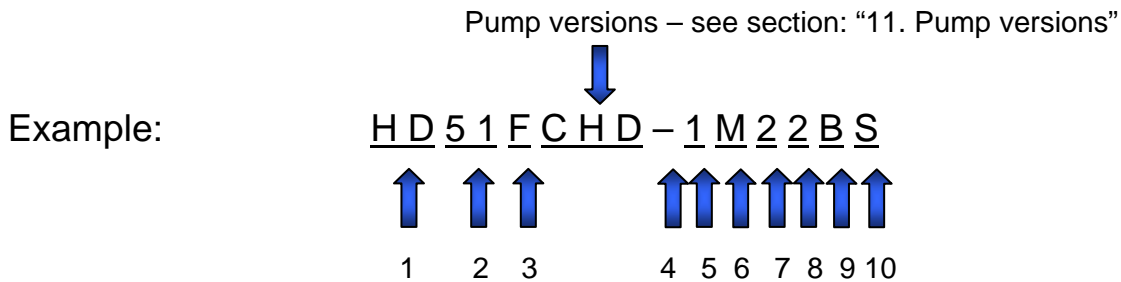

The numbers in the above example refer to the numbers on the next page.

This particular pump's designation is displayed on the pump's name plate – refer to that!

## 5.1.2 Pump models:

### 1) Pump types

<b>GP</b>	"General Purpose"	monoblock cast iron pump
<b>HD</b>	"Heavy Duty"	cast iron pump
<b>PD</b>	"Petrochemical Duty"	carbon steel pump
<b>CD</b>	"Chemical Duty"	stainless steel pump
<b>MD</b>	"Magnetic Drive "	pump with magnetic coupling, made of cast iron, carbon steel or stainless steel

### 2) Pump sizes

<b>26</b>	DN25	- 1"
<b>33</b>	DN32	- 1¼"
<b>41</b>	DN40	- 1½"
<b>51</b>	DN50	- 2"
<b>66</b>	DN65	- 2½"
<b>81</b>	DN80	- 3"
<b>101</b>	DN100	- 4"

<b>126</b>	DN125	- 5"
<b>151</b>	DN150	- 6"
<b>152</b>	DN150	- 6"
<b>201</b>	DN200	- 8"

### 3) Versions

<b>E</b>	Suction/Discharge ports in-line
<b>B</b>	Suction/discharge couplings at 90° angle
<b>R</b>	Relief valve (standard – less valve optional)
<b>D</b>	Heating jacket on head
<b>K</b>	Heating jacket on magnet housing
<b>T</b>	Special clearances
<b>F</b>	Flange
	Other versions, see next page

**4)** - Hyphen

### 5) Material codes for main parts

<u>Code</u>	<u>Type</u>	<u>Pump casing/Covers</u>	<u>Rotor/Idler</u>	<u>Shaft</u>
<b>1</b>	GP/HD	Cast iron	Cast iron	Carbon steel
<b>3</b>	CD	316 SS	329 SS	329 SS
<b>4</b>	PD	Cast steel	Cast iron	Carbon steel

### 6) Lubrication

<b>U</b>	Idler bearing and main bearing lubricated by pump medium
<b>M</b>	Externally lubricated idler bearing and main bearing.

All materials can be used for MD pumps

### 7) Material codes for idler bearing

<u>Code</u>	<u>Idler Bush</u>	<u>Idler Pin; GP-HD-PD</u>	<u>Idler pin: CD</u>
<b>1</b>	Cast iron	Hardened steel	329 SS
<b>2</b>	Bronze	Hardened steel	329 SS
<b>3</b>	Carbon	Hardened steel	329 SS
<b>4</b>	Al.oxide	Cr.oxide coated	Cr.oxide coated
<b>5</b>	Carbon	Al.oxide, polished	Al.oxide, polis
<b>8</b>	Tungsten carbide	Tungsten carbide	Tungsten carbide

### 8) Material codes for main bearing

<u>Code</u>	<u>Bearing Bush</u>	<u>Shaft: GP-HD-PD</u>	<u>Shaft: CD</u>
<b>1</b>	Cast iron	Carbon steel	329 SS
<b>2</b>	Bronze	Carbon steel	329 SS
<b>3</b>	Carbon	Carbon steel	329 SS
<b>4</b>	Al.oxide	Cr.oxide coated	Cr.oxide coated
		<b>Carbon steel</b>	329 SS
<b>8</b>	Tungsten carbide	Coated Carbon steel	Tungsten carbide Coated 329 SS
<b>9</b>	Silicon carbide	SiC casing or Cr.oxide coated Carbon steel	SiC casing or Cr.oxide coated 329 SS
<b>B</b>	Ball bearing	Carbon steel	Not available

### 9) Shaft seal

<b>B</b>	Packing rings, Teflon-impregnated
<b>2</b>	Mechanical shaft seal, EN12756-KU, O-ring or bellows
<b>22</b>	Double mechanical shaft seal, <b>For MD pumps only:</b>
<b>/2</b>	Magnet length 2 cm
<b>/3</b>	Magnet length 3 cm
<b>/6</b>	Magnet length 6 cm
<b>/8</b>	Magnet length 8 cm
<b>/10</b>	Magnet length 10 cm N Magnet Material: NdFeB C Magnet Material: SmCo

### 10) Special configurations

<b>S</b>	All special configurations are marked with: S
----------	---

## ROTAN pump configuration options

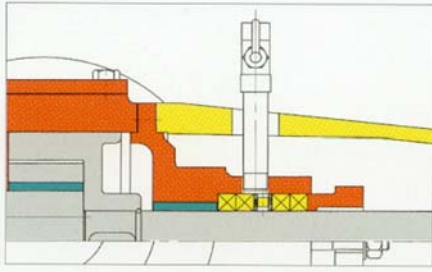
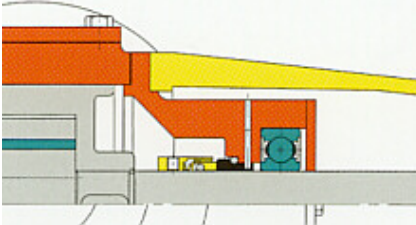
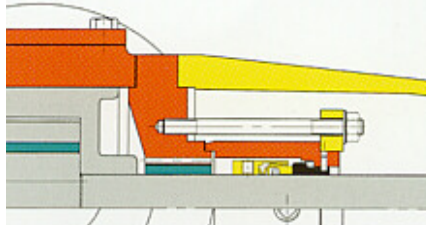
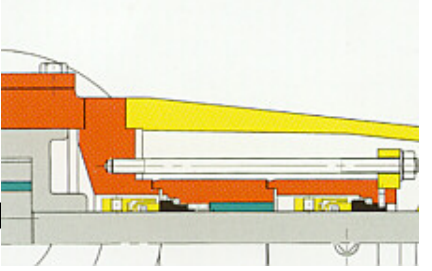
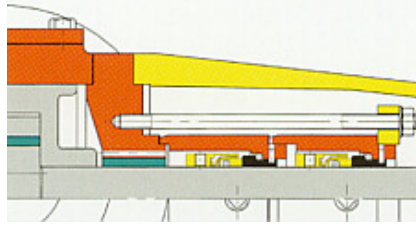
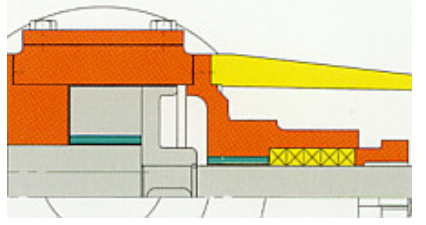
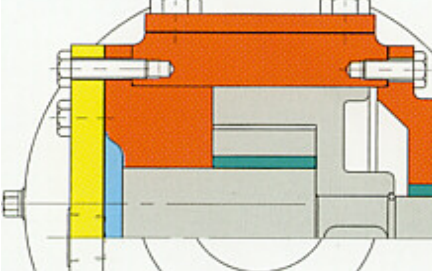
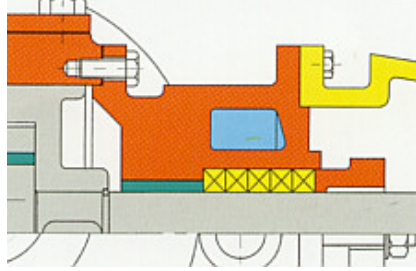
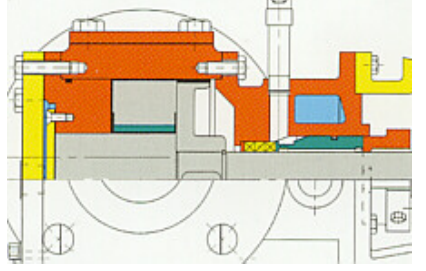
		
<p>Sealing with stuffing box, with or without lantern ring for use of external lubrication. Used for high viscosities and where leakages are allowed.</p>	<p><b>M – GP/HD</b> Sealing with mechanical shaft seal, DIN 24960 – KU, combined with a ball bearing as main bearing. Used where only minor leakage is allowed.</p>	<p><b>M – PD/CD</b> Sealing with mechanical shaft seal, DIN 24960 – KU, combined with a slide bearing as main bearing. Used where only minor leakage is allowed.</p>
		
<p><b>MM (tandem) - MMP (back to back)</b> Double mechanical shaft seals, DIN 24960 – KU, in tandem or back-to-back, with main bearing in the barrier fluid. Used where no leakages are allowed. Up to 90 PSI differential pressure allowed.</p>	<p><b>MMW (tandem) - MMPW (back to back)</b> Double mechanical shaft seals, DIN 24960 – KU, in tandem or back-to-back, with main bearing in the liquid. Used where no leakages are allowed. UP to 250 PSI differential pressure allowed.</p>	<p><b>T</b> Special clearances increase of tolerances used for liquids with a viscosity above 7,500 cSt. Or a temperature above 300°F</p>
		
<p><b>D</b> Heating jacket on the front cover, often required prior to start-up when pumping high viscosity liquids and liquids which tend to solidify.</p>	<p><b>K</b> Heating jacket on the rear cover often required prior to start-up when pumping high viscosity liquids and liquids which tend to solidify. This jacket is also used as a seal-cooling jacket.</p>	<p><b>CHD</b> Combination of special clearances and heating jackets together with external lubrication of the main bearing, used in the chocolate industry.</p>

		
<p>R Safety valve, (single acting lone direction), used to protect the pump and the complete installation against excessive pressures.</p>	<p><i>Special configurations</i> Example: Mounting of a cartridge seal, single or double, is semi standard.</p>	<p>Lubrication Idler bearing and main bearing externally lubricated. Used when pumping non-lubricating or high viscosity fluids.</p>

Figure 6: The codes of the various pump versions together with an explanation of what they mean.

## Transporting the pump

The pump must be secured properly on pallets or similar medium before transport and shipment.

The pump must be transported with the usual degree of consideration, to avoid exposing it to impact and pressure.

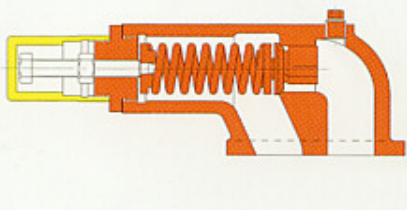
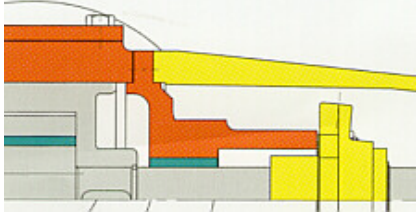
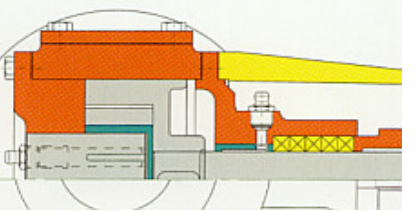
## Lifting the pump

If the pump's weight is more than the permitted allowance of kilos/pounds that people may lift according to local regulations, it must be lifted mechanically.

We refer to the prevailing national rules at the location!

The table below – Figure – shows the weight of the various pump types and pump sizes.

Pump weight in kg./lbs. - excl. valve ( incl. valve )						
Pump size	Unit	Pump type				
		GP/CC	HD	PD	CD	MD
26	Kg.	11 (13)	5.5 (7.5)	7 (9)	7 (9)	29 (31)
	Lbs.	25 (29)	13 (17)	16 (20)	16 (20)	64 (69)
33	Kg.	12 (14)	6 (8)	10 (12)	10 (12)	30 (32)
	Lbs.	27 (31)	14(18)	22 (27)	22 (27)	67 (71)
41	Kg.	20 (22)	14 (16)	18 (20)	18 (20)	40 (42)
	Lbs.	44 (49)	31 (36)	40 (44)	40 (44)	89 (93)
51	Kg.	50 (56)	35 (41)	36 (42)	36 (42)	90 (96)
	Lbs.	110 (124 )	79 (91)	80 (93)	80 (93)	199 (212)
66	Kg.	55 (61)	40 (46)	43 (49)	43 (49)	95 (101)
	Lbs.	122 (135)	89 (102)	95 (108)	95 (108)	210 (223)
81	Kg.	80 (90)	65 (75)	70 (80)	70 (80)	180 (190)
	Lbs.	177 (199)	144 (166)	155 (177)	155 (177)	397 (419)
101	Kg.	105 (115)	90 (100)	96 (106)	96 (106)	200 (210)
	Lbs.	232 (254)	199 (221)	212 (234)	212 (234)	441(463)
126	Kg.	-	140 (160)	152 (172)	152 (172)	350 (370)
	Lbs.	-	309 (353)	336 (380)	336 (380)	772 (816)
151	Kg.	-	190 (210)	205 (225)	205 (225)	400 (420)
	Lbs.	-	419 (463)	452 (496)	452 (496)	882 (926)
152	Kg.	-	280 (340)	335 (395)	335 (395)	-
	Lbs.	-	618 (750)	739 (871)	739 (871)	-
201	Kg.	-	460 (520)	500 (560)	500 (560)	-
	Lbs.	-	1015 (1147)	1103 (1235)	1103 (1235)	-

Figure 7: Table showing the weight in kg. and lbs. of the various pump types in the various pump sizes.  
Weights excl. valve – the figures in brackets incl. valve.  
Weights excl. motor/gear and base frame (if any).



Lift the pump mechanically, if the pump's weight is more than the permitted allowance of kilos/pounds that people may lift.



Do not place fingers in the pump's ports when lifting or handling the pump.



The pump must be lifted using stable suspension points, so that the pump is evenly balanced and the lifting straps are not lying over sharp edges.



The pump must be lifted in accordance with the lifting instructions Figure – Figure10



Motors fitted with lifting eyes must not be used to lift the whole pump, only to lift the motor separately

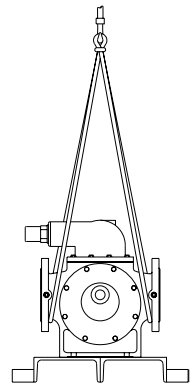
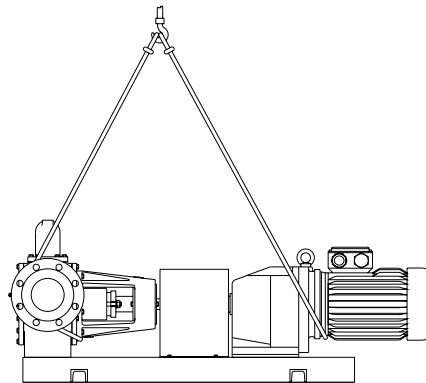
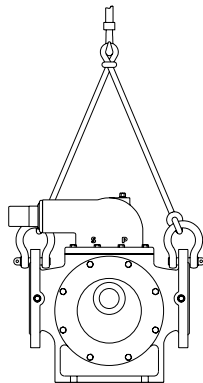
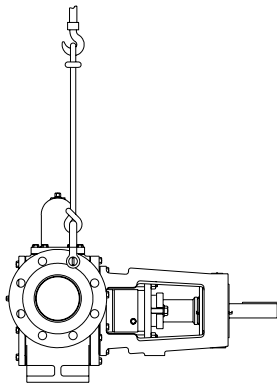

Figure 8:  
Lifting instructions for pump with free shaft end.  
Attach 2 shackles to the flanges on the pump  
for lifting straps.  
The shackles must be placed in the flanges  
at the pump's centre of gravity.

Figure 9:  
Lifting instructions for pump with gear motor.

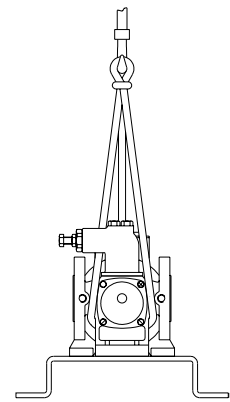
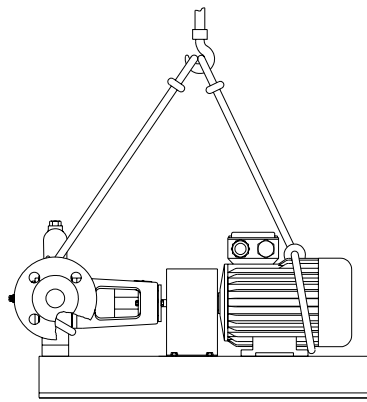
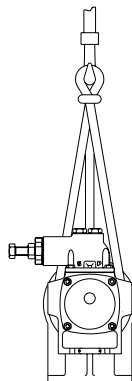
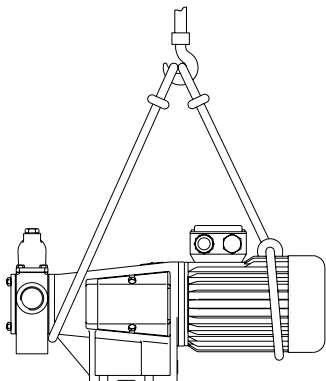

Figure 10:  
Lifting instructions for GP pump type.

Figure 11:  
Lifting instructions for pump with motor.

## Storage, long-term preservation and frost protection of the pump

Rotan pumps are protected against corrosion at the factory.

The pumps are preserved internally using oil, and pumps for the food industry are preserved using vegetable oil.

External, non stainless surfaces are covered with primer and protective paint – except the shaft. Flanges and pipe couplings are closed using plastic plugs.

This protection will last for approximately six months, on the condition that the pump is stored indoors in a dry, dust-free, non-aggressive atmosphere.

### Storage

When stored for a long periods of time, the pump must be inspected after no more than six months – depending on the storage conditions. The pump shaft must however be turned manually approx. every 4 weeks to avoid standstill damages to bearings and seals.

#### **Avoid storage:**

- in an environment containing chloride
- on foundations with continuous vibrations, as the bearings might be damaged
- in unventilated rooms

#### **Recommended storage:**

- indoors in a dry, dust-free, non-aggressive atmosphere
- in a well-ventilated room to prevent condensation
- flanges and pipe couplings closed using plastic plugs
- pump packed if necessary in plastic film and with moisture-absorbing Silica Gel bags

## Preservation procedure

Make sure that the pump does not corrode or dry out, as drying out between the sliding surfaces of the bearings may cause damage when the pump is put into operation.

Preservation of the pump is necessary on untreated surfaces – both external and internal.

Rustproof surfaces do not require any special protection.

1. If the pump has been in operation it must be emptied – see section entitled “Emptying and cleaning the pump”.
2. Rinse the pump with clean, hot water, then empty it and dry it.  
The pump must not be left with damp surfaces on the inside.
3. Spray on an anti-corrosion oil, such as: Q8 Ravel D/EX, Mobilarma 777 or equivalent.  
It is also possible to use acid-free oil, such as hydraulic oil.  
Pumps fitted with EPDM rubber seals do not tolerate mineral oil-based oils and certain food oils. As an alternative, in this instance you can use silicon oil or a fire-resistant type of polyglycol-based hydraulic oil.  
This can be applied by spraying in through both the inlet and outlet ports – if necessary by means of compressed air.
4. For pumps intended for integration in an existing pipe system, an anti-corrosion oil can be sprayed in through the manometer holes in the inlet and outlet ports, or through the bore that has been provided to connect a manometer.
5. Fill the pump with sufficient oil for the oil to start running out of the pump.
6. Rotate the pump manually, so that all internal surfaces are lubricated.
7. This process must be repeated every six months.

## Frost protection

Pumps that are out of operation during periods of frost must be emptied of liquid to avoid frost damage.

You can use anti-frost liquids, but you must make sure that the elastomers used in the pump will not be damaged by the liquid used.

## Installation

All items in this section must be read and observed when installing ROTAN pumps.

## Selecting the motor

The flange motor in CC and GP pumps must have a locked bearing at the end of the shaft end – as well as vertically positioned pumps, to ensure that the pump's axial clearance falls within permitted parameters.

## Connecting the motor and the pump



If you intend to use the pump in a potentially explosive environment, the pump must be connected to an explosion-proof motor.



Carefully shield the coupling between the pump and motor.

1. Before connecting the motor and the pump, check that the pump shaft can revolve easily and regularly.
2. When connecting the motor with the pump, you must make sure that the pump shaft and the motor shaft are on precisely the same center line and that there are a few mm/(about 0.10 inches) between the shaft ends, as otherwise you run the risk of the pump being destroyed during operation.
3. Pump types HD, CD, PD and MD must be connected to the motor by means of an elastic coupling.
4. If a ROTAN standard coupling is used, the pump and the motor are aligned as described in the following section.  
Other couplings are fitted and aligned in accordance with the coupling supplier's instructions – refer to these!

## Aligning the motor and the pump

If a ROTAN standard coupling is used, the motor and the pump are aligned as follows. Other couplings are aligned in accordance with the coupling supplier's instructions with regard to the maximum permitted tolerances for eccentricity and non-parallelism.

1. Check the centering between the pump shaft and the motor shaft by means of a straightedge. Place the straightedge over the two coupling pieces on the circumference – 90° apart. Any misalignment will become evident in the form of a gap of light between the straightedge and the coupling hub.
2. Centering may deviate by a maximum of 0.05 mm/0.002 inches when both halves of the coupling rotate
3. Check the parallelism/gap between the halves of the coupling, using an air gap gauge. The gap may be a maximum of 0.5° – or when both halves rotate the gap deviation may not exceed 0.05 mm/0.002 inches on the same point
4. Inserting suitable intermediate layer of material between the pump's or the motor's base and base frame corrects alignment.

Insufficient alignment between pump and motor causes increased wear on the coupling elements.

## Axial clearance



Set the axial clearance to prevent heat generation and the subsequent risk of explosion.

After coupling and alignment between motor and pump has been completed, the pump's axial clearance must be set correctly, see section entitled "Setting the axial clearance".

The axial clearance does not have to be set for pumps purchased with a motor, as this is set in the factory.

## Horizontal/vertical positioning of the pump

ROTAN pumps can be positioned horizontally or vertically.

### 10.4.1 Horizontal positioning of the pump

The standard position is for the pump to be horizontal to the foundation, i.e. with a horizontal pump shaft and the valve/blank flange on top.

The pump must not be positioned with the suction port facing down, as the pump would then lose seal liquid and thereby its suction priming ability.

### 10.4.2 Vertical positioning of the pump



Position and fit vertical pumps as described below, to avoid dry running and the subsequent risk of explosion in EEx pumps.

A ROTAN pump should as a rule *not* be positioned vertically, i.e. with a vertical pump shaft and the motor on top. A pump may only be positioned vertically if it has been *specialy* produced for this purpose at the factory.

If a pump is positioned vertically, it must be placed at the lowest point in the pipe system, so that it retains its priming ability – dry running is not permitted.

## Positioning of the pump on the foundation

There must, whenever possible, be plenty of room around the pump to allow for repairs and maintenance.

Figure shows the minimum distance to the wall to ensure that removal of the front cover is possible.

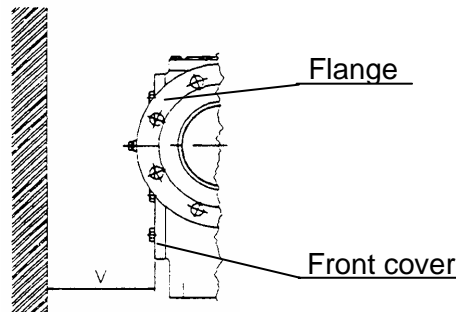

Distance between pump and wall											
Pump size	26	33	41	51	66	81	101	126	151	152	201
V-dist. in mm	50	60	65	70	80	100	115	140	165	180	215
V-dist. in inches	2	2.4	2.6	2.8	3.2	4	4.6	5.6	6.5	7.1	8.5

Figure 12: The minimum distance to the wall – V-dist. in mm and inches– to enable removal of the front cover. The table shows the size of the V-dist. for the various pump types.

This distance must be observed for both horizontally and vertically positioned pumps.

The pump must be placed on a solid, vibration-free foundation with a level surface and bolted firmly to the floor.

If the surface is not level, compensation must be made for this using a suitable intermediate layer, so that preloads are avoided.



Bolt the pump securely to the foundation.

You must also take into account the pump's suction lift – see section entitled "Suction lift" under "Technical specifications".

If the pump has a soft shaft seal, a drainage pipe must be connected to the bracket's drainage hole.

Vertical pumps are bolted securely to an existing wall or a vertically cast foundation. The minimum distance between the front cover and the floor can be seen in Figure 12.

## Before connecting the pipes

**The pump should be filled with liquid before it is started. Before the pipes are fitted, the pump is filled with a volume of liquid that enables the liquid to start running out of the pump. Vertically positioned pumps are filled with liquid after the pipes are connected.**



Clean out any impurities from the pipe system before the pump is connected to it.



Remove the protective plugs from the pump ports before connecting the pipes.

The pump must be installed so that there is no tension between the pipe and the pump casing. The permitted loads on the pump flanges are described in the following section, “External loads on pump flanges”.

### 10.6.1 External loads on pump flanges

There must be no tension between the pipe and the pump casing when the pump is installed. Tension in the pump casing as a result of preloaded pipes will create a significant increase in the rate of wear.

Pipes and wires must be supported as close to the pump casing as possible.

The diagram below shows the maximum permitted external force and torque that can be applied to the pump flanges.

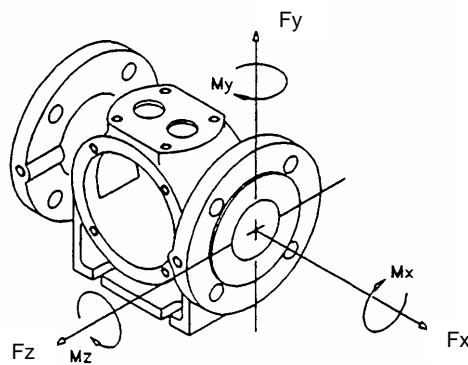

Figure 13: The location of forces and torque on the pump casing.

Maximum external force and torque loads								
Pump size	Force				Torque			
	$F_{(x,y,z)}$ N	$F_{(x,y,z)}$ Lbf	$F_{(Total)}$ N	$F_{(Total)}$ Lbf	$M_{(x,y,z)}$ Nm	$M_{(x,y,z)}$ Lbfft	$M_{(Total)}$ Nm	$M_{(Total)}$ Lbfft
26	190	42.7	270	60.7	85	62.7	125	92.2
33	220	49.5	310	69.7	100	73.8	145	106.9
41	255	57.3	360	80.9	115	84.8	170	125.4
51	295	66.3	420	94.4	145	106.9	210	154.9
66	360	80.9	510	114.7	175	129.1	260	191.8
81	425	95.5	600	134.9	215	158.6	315	232.3
101	505	113.5	720	161.9	260	191.8	385	284
126	610	137.1	870	195.6	325	239.7	480	354
151 / 152	720	161.9	1020	229.3	385	284	565	416.7
201	930	209.1	1320	296.7	500	368.8	735	542.1

Figure 14: The maximum permitted external forces and torque that may be applied to pump flanges for the various pump sizes. x, y and z are described in Figure 13.

The forces F (Total) in N/Lbf and torque M (Total) in Nm/Lbfft are calculated as follows:

$$F_{(total)} = \sqrt{F_x^2 + F_y^2 + F_z^2}$$

$$M_{(total)} = \sqrt{M_x^2 + M_y^2 + M_z^2}$$

- on the condition that the x, y and z components cannot all have the maximum value at the same time.

If the maximum permitted force and torque loads specified cannot be observed, compensators must be built into the pipe system.

When pumping hot liquids, the pipes must always be fitted with compensators, so that the pipes and the pump are able to expand.

If you require a ROTAN pump with belt drive, the permitted power on the outlet shaft is provided on request.

## 10.6.2 Flange coupling



Flange couplings must always be undertaken by skilled professionals.



Achieve parallelism between the flanges and observe the maximum tightening torque to prevent tension in the pump casing.

1. Before connecting the flange, check that the flanges are parallel, as any variance in parallelism will create tension in the pump casing. Aligning the pipe system or fitting compensators achieves parallelism.
  2. Select the bolt size for the flanges on the basis of the pump size in the table in Figure 15. You should not use bolts with a yield stress of more than 240 N/mm<sup>2</sup>, corresponding to quality 4.6 – for pumps manufactured in grey cast iron, material code “1”.
  3. Find the maximum tightening torque in the table in Figure 15. Please note that the table contains the maximum tightening torque. The necessary tightening torque depends on: packing, form, material and the pump liquid’s temperature. The values in column A are valid for pumps manufactured in grey cast iron – material code “1”. The values in column B are valid for pumps manufactured in steel – material codes “3” or “4”.
3. Cross-tighten the bolts using the uniform tightening torque shown in the table below.

Bolt size/maximum tightening torque					
Pump size	Bolt*	Maximum tightening torque			
		A Nm	A Lbfft	B Nm	B Lbfft
26	M12	30	22.1	80	59
33-126	M16	75	55.3	200	147.5
151-201	M20	145	106.9	385	284

Figure 15: The bolt sizes available for connecting flanges, together with the maximum tightening torque depending on the pump size and material stated.

Columns A contains the maximum tightening torque for pumps manufactured in grey cast iron – material code “1”.

Columns B contains the maximum tightening torque for pumps manufactured in steel – material codes “3” or “4”.

\*You should not use bolts with a yield stress of more than 240 N/mm<sup>2</sup>, corresponding to quality 4.6, for pumps manufactured in grey cast iron – material code “1”.

### 10.6.3 Threaded coupling



Threaded couplings must always be made by skilled professionals.



Connecting a pump with an internal thread to a pipe with a conical thread can cause the pump casing to burst if the coupling is over-tightened.

We recommend that you connect pumps with an internal thread to pipes with a cylindrical thread.

### By-pass valve

If the pump has been bought with a valve, it is always fitted to the pump in the factory. As standard the valve is fitted with **S** to the left and **P** to the right, viewed from the pump's front cover.

When installing the pump, the valve must be turned correctly with regard to the desired direction of circulation, see section entitled "Positioning the valve".



Fit the by-pass valve correctly with regard to the desired direction of circulation

### Temperature sensor

When installing the pump the temperature sensor has to be set before the pump is started, as otherwise there is a risk of explosion.



Connect and pre-set always the temperature sensor before starting up the pump



Set the temperature sensor to 80% of the pump's max. surface temperature

## Emergency stop



Fit the pump unit with an emergency stop

If the pump is fitted as part of a total system, this must be provided with an emergency stop. The emergency stop is not included in DESMI's delivery.

### When installing the pump, the emergency stop must be:

- Designed, set up and installed, and function in accordance with the prevailing standards and directives
- Positioned within easy reach, so that it is accessible to the operator/engineer during repairs, adjustment and maintenance of the pump
- Be tested regularly to check that it is in full working order

## 10.10. Electrical coupling



Electrical couplings must always be established by authorized professionals, in accordance with the prevailing standards and directives.



Set the protective motor switch.  
Set the protective motor switch maximum to the motor's rated current.

### When installing the pump, check:

- That the local mains voltage is the same as stated on the motor's name plate.
- That the motor's direction of rotation corresponds with the desired pump direction. When the pump unit is viewed from the motor end, and you require the pump direction to the left, the motor's rotation must be clockwise.

## Monitoring



Connect any monitoring and safety systems that are necessary for safe operation.



Connect and adjust any monitoring and safety systems – manometers, flow meters, etc. – according to the operating condition

## 11. Before starting the pump

<b>Before starting the pump, check:</b>
<ul style="list-style-type: none"> <li>• That the pump shaft can be turned around freely.</li> </ul>
<ul style="list-style-type: none"> <li>• That the pump is connected to an explosion-proof motor, if the pump is set up in a potentially explosive atmosphere. That the pump's and the motor's name plates are labeled with explosion protection.</li> </ul>
<ul style="list-style-type: none"> <li>• That the pump and motor are aligned precisely – see section entitled “Alignment between motor and pump”.</li> </ul>
<ul style="list-style-type: none"> <li>• That the bearings – if they have lubrication nipples – are lubricated.</li> </ul>
<ul style="list-style-type: none"> <li>• That the ball bearings' maximum service life is observed.</li> </ul>
<ul style="list-style-type: none"> <li>• That the thread of the temperature sensor has not broken off during transportation, handling or installation – if the pump is fitted with temperature sensor</li> </ul>
<ul style="list-style-type: none"> <li>• That the temperature sensor is connected</li> </ul>
<ul style="list-style-type: none"> <li>• That all isolating valves in the suction and pressure pipe are fully open, to avoid the pressure being too high and the pump running dry.</li> </ul>
<ul style="list-style-type: none"> <li>• That any by-pass valve is fitted correctly – see section entitled “Positioning the valve”.</li> </ul>
<ul style="list-style-type: none"> <li>• That any by-pass valve is adjusted to the correct opening pressure – see section entitled “Setting the by-pass valve”.</li> </ul>
<ul style="list-style-type: none"> <li>• That the pump casing is filled with liquid to ensure the ability to self-prime – see section entitled “Before connecting the pipe”.</li> </ul>
<ul style="list-style-type: none"> <li>• That there is no coagulated liquid in the pump or the pipe system – after the last operation – that may cause blockage or breakdown.</li> </ul>
<ul style="list-style-type: none"> <li>• That the necessary monitoring and safety systems are connected and adjusted according to the operating conditions.</li> </ul>

### Before starting after preservation

If the pump has been in storage for a long period of time, you must also check the following:

<b>Before starting – after preservation – check:</b>
<ul style="list-style-type: none"> <li>• That the pump is not corroded or dried out – see section entitled “Storage and protection of pump”. That slide bearings and the shaft seal's sliding surfaces are not dry. This check is performed by turning the pump shaft gently.</li> </ul>
<ul style="list-style-type: none"> <li>• That any preservative or anti-frost liquid is cleaned off before starting the pump – if these are not compatible with the pump liquid.</li> </ul>
<ul style="list-style-type: none"> <li>• That elastomers are replaced if they have been damaged by the anti-frost liquid used.</li> </ul>
<ul style="list-style-type: none"> <li>• That ball bearings and any elastomers are replaced if the pump has been in storage for more than 6 years, as the lubricating grease used for elastomers and ball bearings have a limited service life.</li> </ul>

## After starting the pump

**ROTAN pumps may only run without liquid flow for the short period required for self-priming – with regard to the slide bearings and shaft seals.**

<b>After starting the pump, check:</b>
• That the pump is drawing the liquid.
• That the speed is correct.
• That the direction of rotation is correct. Viewed from the motor side, liquid is pumped to the left when the shaft rotates clockwise.
• That the pump is not vibrating or emitting a jarring sound.
• That the stuffing box and bearings are not becoming hot. If the pump has been fitted with lip seals, these will normally cause the shaft to heat up during the ring's running-in period, which lasts approx. 2 hours.
• That there are no leaks by the pump.
• That the mechanical shaft seal is fully sealed. Stuffing boxes with packing rings may, however, permitted a low level of leakage – 10-100 drops of leakage per minute – see section entitled “Adjusting the soft shaft seal”.
• That the operating pressure is correct.
• That the by-pass valve opens at the correct pressure.
• That the pressure in the heating jacket does not exceed 10 bar/145 psi – if the pump has
• That the magnetic clutch (type MD) is not slipping and thus causing an inadequate flow, and that the temperature in the magnetic clutch does not exceed the permissible value.
• That the power consumption is correct.
• That all monitoring equipment is in full working order.
• That any pressurized water pipes, heating/cooling systems and lubricating systems, etc. are operating and in full working order.
• Running in the soft shaft seal – see section entitled “Running in the soft shaft seal”.

## Running in the soft shaft seal – when starting the pump



A soft shaft seal may only be used on pumps in potentially explosive environments, if the soft shaft seal is equipped with thermal sensors to control the temperature.

When starting a new pump, the shaft seal must be run in as described below:

1. Once the pump has started, the shaft seal must leak more than 200 drops per minute to saturate the rings.
2. When the shaft seal is saturated – after approx. 30 minutes' operation – the packing gland screws must be tightened gradually, so that the leakage is reduced.
3. Check that the gasket does not become hot.  
If the gasket becomes hot, loosen the packing rings slightly, after which you must check that the temperature is falling.
4. When the leakage is between 10 – 100 drops per minute, do not tighten the screws any more.  
The number of drops per minute depends on the pump size, pressure and speed.
5. The gasket must not be tightened so much that there is no leakage.  
The soft shaft seal must leak continuously.
6. The leakage rate must be checked at regular intervals, see section entitled "Maintenance".  
If necessary, see also the section entitled "Adjusting the soft shaft seal".

## By-Pass valve

ROTAN pumps are supplied both *with* and *without* ROTAN by-pass valve.

The by-pass valve protects the pump and motor in case of acute pulsating excess pressures in the system. The valve does **not** protect the piping **only** pump and motor.



The by-pass valve is **not** approved to protect the piping system and consequently must **not** be employed for that purpose



The piping system **must** be protected against excess pressure in another way than using the ROTAN by-pass valve



If it is possible to cut off the pump pressure line this pressure line **must** be equipped with a safety valve that is able to cope with the entire amount of liquid, as pumping against a cut off discharge line will cause "unlimited" pressure accumulation.

Do **not** use the ROTAN by-pass valve as a "pressure-retaining-valve" for constant pressure regulation.

If constant pressure regulation is required an alternative solution should be applied e.g. frequency converter or gearbox.



Do **not** use the valve for constant pressure regulation - as a "pressure-retaining-valve"



Do **not** circulate the liquid through the by-pass valve for a longer period of time as this may cause excessive heating of the pump and pumped liquid and ultimately destroy the pump



Do **not** circulate the liquid through the by-pass valve for a longer period of time as this may cause excessive heating of the pump and pumped liquid and ultimately constitute an explosive hazard

The ROTAN by-pass valve is also available as a double-acting by-pass valve – see Fig.

In case a pump has to be able to pump in both directions a double-acting by-pass valve has to be mounted.

Pump types GP, HD, and CD, sizes 26, 33, 41, 51, 66, 81, 101, 126, and 151 can be mounted with double-acting by-pass valve.



In case the pump has to be able to pump in both directions, mount a double-acting by-pass valve

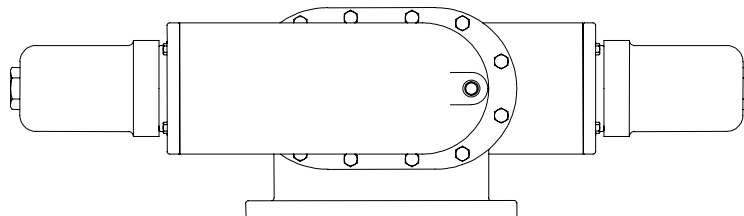

Figure 16: Shows a double-acting by-pass valve.



Provided a pump is ordered for operation in an explosion hazardous environment, it is **always** equipped with a ROTAN bypass valve from the factory.



Pumps for operation in hazardous explosive environments **must** be equipped with a ROTAN bypass valve.

Please note that the characteristics of certain types of liquid or heated liquids may block the function of the bypass valve - e.g. paint, chocolate, asphalt etc.

The obstruction of the valve may be caused by particles in the liquid or the fact that the liquid has been heated and subsequently coagulates when re-circulating in the valve.

In such cases we advise against the use of the ROTAN bypass valve and recommend that another device be used.

In cases where the liquid may block the function of the bypass valve another, however equivalent, device than the ROTAN bypass valve should be used.

Please note that a special ROTAN bypass valve with connection for heating to prevent coagulation of the liquid is available.

Should the pump, according to customer's wish, be supplied without the ROTAN bypass valve, another equivalent device must be used in order to secure that the pump does not build up a pressure higher than the max. Pressure specified at order and the max.



Pumps without the ROTAN bypass valve must be equipped with an equivalent device in order to protect pump and motor.

Pumps supplied without the ROTAN bypass valve are mounted with a blind flange.



The ROTAN bypass valve is always supplied with a bore for connection of pressure gauge. The bore is blinded with a pipe plug.



## Valve configurations

For pumping liquids at high temperatures, the valve can be supplied with a heating jacket. The heating jacket prevents the pump liquid from coagulating when passing through the valve.

## Positioning the valve

The by-pass valve is fitted with an inlet and an outlet. The inlet and outlet are named as follows:

Inlet       Suction side       **S**

Outlet       Pressure side       **P**

The suction side and pressure side are indicated on the valve by the letters **S** and **P** – see Figure 17.

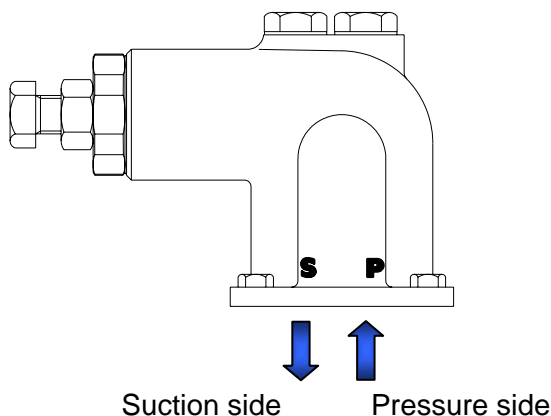

Figure 17: Shows how **S** for suction side and **P** for pressure side are indicated on the valve.

If the pump has been bought with a valve, it is always fitted to the pump in the factory. As standard the valve is fitted with **S** to the left and **P** to the right, viewed from the pump's front cover.

**Before the pump is installed in a pipe system, the valve must be positioned correctly with regard to the desired direction of circulation, as incorrect positioning of the valve will stop it from working.**

The valve's **S** inlet must be placed by the pump's suction side, so that the regulating screw points towards the suction side.



Position the valve correctly, with **S** over the inlet/suction side and **P** over the outlet/pressure side.

### Operating principle – valve

When the pressure increases in the pump, the pump liquid is forced into the valve's pressure side – **P**.

If the valve's preset pressure is exceeded, the internal key is depressed, after which the pump liquid is forced out of the outlet side of the valve and down into the pump again, thus creating a recirculation of the pump liquid.

This recirculation may not last for a long period of time, as this will cause the liquid and the pump to heat up significantly.



The pump must not pump with the valve open for a long period of time



Re-circulation through the by-pass valve over a long period of time causes the liquid and the pump to heat up significantly.



Re-circulation through the by-pass valve over a long period of time can destroy the pump.

### Setting the by-pass valve

The by-pass valve is set by adjusting the regulating screw, which is located on the end of the valve, see Figure 18.

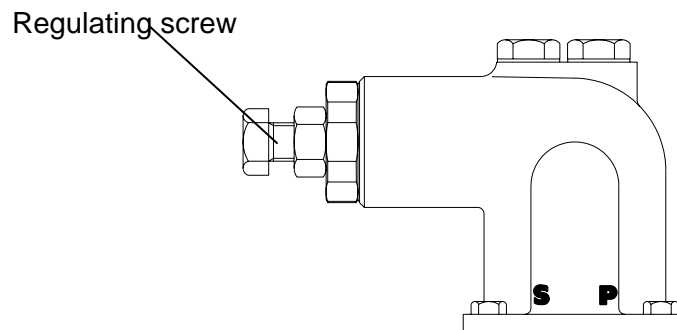

Figure 18: The location of the regulating screw on the ROTAN by-pass valve.  
The by-pass valve is always set at the factory.

The valve is set in accordance with either

- customer instructions
- or DESMI's default setting

If the valve has been set in accordance with customer instructions, this setting must correspond with the other instructions included in this user manual, in the section entitled "By-pass valves".

If the setting is DESMI's default setting, this has been made on the basis of the table entitled Figure 20.

All settings of the regulating screw must be made on the basis of the table entitled Figure 20– or by pressure gauge.

**The default setting of the valve has been made as follows:**

1. The valve has a number, and this number can be seen on the pump's name plate
2. The valve number found is contained in the table entitled Figure 20 – if necessary by means of pump type and pump size, as stated on the far left of the table
3. Next to the valve number there are several different setting measurements.  
The setting value corresponding to the maximum operating pressure in the table is the one selected.

**Example:**

HD26 – Valve no.: 3891 ➡ max. operating pressure: 4 bar/58 psi ➡

*A-value = 8 mm./0.31 inches*

The default setting in the factory is always based on the maximum operating pressure stated in the table in Figure 20.

In the case of valves that have been set in accordance with customer instructions, you can identify the operating pressure to which the valve has been set as follows:

**The operating pressure to which the valve has been set:**

1. The valve has a number, and this number can be read on the pump's name plate.
2. The valve number obtained is contained in the table in Figure 20 – if necessary by means of pump type and pump size, as stated on the far left of the table.
3. Measure the valve's setting value as shown in Figure 20.
4. The value can be seen in the table on the basis of the valve number obtained, and the operating pressure is read off according to this.

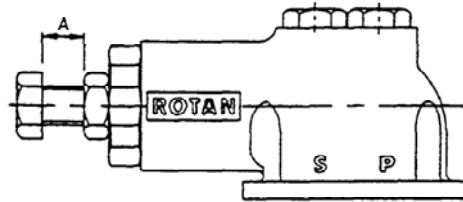

Figure19: The setting value "A" for ROTAN valves.

Valve settings										
		Operating pressure in bar/psi								
		bar:	2	4	6	8	10	12	14	16
		psi:	29	58	87	116	145	174	203	232
Pump type/ Pump size	Valve no.	Unit	Setting value A in mm./inches							
HD/GP/MD 26-33-41	6345,6453, 6347	mm.	12	8						
		in.	0.47	0.31						
	6141, 6142	mm.		14	13	11.5	10			
		in.		0.55	0.51	0.45	0.39			
	6346,6363, 6349	mm.					15.5	14	13	11.5
		in.					0.61	0.55	0.51	0.45
PD 26-33-41	6425, 6428	mm.	11.8	9.1						
		in.	0.46	0.36						
	6429	mm.		11	8.7	6.5	4.3			
		in.		0.43	0.34	0.26	0.17			
	6427, 6430	mm.				15.5	14	13	11.5	
		in.				0.61	0.55	0.51	0.45	
CD/MD 26-33-41	6416, 6419	mm.	11.8	9.1						
		in.	0.46	0.36						
	6417, 6420	mm.		11	8.7	6.5	4.3			
		in.		0.43	0.34	0.26	0.17			
	6418, 6421	mm.					10	9	8	7
		in.					0.39	0.35	0.31	0.28
HD/GP/PD /MD 51-66	6143, 6321	mm.	22.5	12.5						
		in.	0.89	0.49						
	6312, 6322	mm.	25.5	19.5	13.5					
		in.	1.00	0.77	0.53					
	6313, 6323	mm.			24.5	22	19.5	16.5	14	
		in.			0.96	0.87	0.77	0.65	0.55	
CD/MD 51-66	6153, 6396	mm.	27.5	20.5	13					
		in.	1.08	0.81	0.51					
	6155	mm.			21.5	17.5	13.5			
		in.			0.85	0.69	0.53			
	6157	mm.					19.5	16	13	10
		in.					0.77	0.63	0.51	0.39

HD/GP/PD /MD 81-101	6314	mm.	11	0					
		in.	0.43	0					
	6144	mm.		12.5	6				
		in.		0.49	0.24				
6315	mm.			14	10.5	6.5			
	in.			0.55	0.41	0.26			
6316	mm.					14.5	12	9.5	
	in.					0.57	0.47	0.37	
CD/MD 81-101	6337	mm.	21.5	7					
		in.	0.85	0.28					
	6154	mm.	28.5	20.5	12.5				
		in.	1.12	0.81	0.49				
	6156	mm.		28.7	24.8	21	17.1		
		in.		1.13	0.98	0.83	0.67		
6158	mm.					23	20.4	17.7	
	in.					0.91	0.80	0.70	
HD/PD/MD 126-151	6305	mm.	41.5	30	19				
		in.	1.63	1.18	0.75				
6226	mm.			34	28	22			
	in.			1.34	1.10	0.87			
CD/MD 126-151	6338	mm.	40	27	14				
		in.	1.57	1.06	0.55				
	6267	mm.			31.5	24.5	17.5		
		in.			1.24	0.96	0.69		
HD/PD/MD 152-201	6318	mm.	62	55	47				
		in.	2.44	2.17	1.85				
	6319	mm.			49	45	41		
		in.			1.93	1.77	1.61		
CD/MD 152-201	6340	mm.	61	52	43				
		in.	2.40	2.05	1.69				
	6341	mm.		50	45	40	35		
		in.		1.97	1.77	1.57	1.38		

Figure20: Setting value "A" in mm/inches, based on the pump type/pump size/valve number and the valve's operating pressure in bar/psi.



Any change to the pump's operating pressure must be followed by a change to the valve's setting.

If the valve is not reset, this will mean either

- that the valve's safety function fails, with the effect that there is a risk of pressure accumulation
- that the valve remains open permanently, creating a significant heating up of the pump and pump liquid – which must not last for a long period of time



The liquid volume may not circulate through the by-pass valve for a long period of time.

Circulation over a long period of time through the by-pass valve causes a significant heating up of the pump and pump liquid, and this can create a risk of explosion.



The liquid volume may not circulate through the by-pass valve for a long period of time. Circulation through the by-pass valve over a long period of time can destroy the pump



The by-pass valve must never be set or adjusted during operation.



Whenever the valve is set or readjusted, the regulating screw must be repacked with thread tape.

## Pump liquids

### Hot liquids

When pumping hot liquids at high temperatures, proper procedures must be taken to prevent any danger of injury caused by touching or standing close to the pump.



The pump must be shielded when pumping hot liquids that create a surface temperature on the pump of more than +80°C/176°F.  
A warning sign must be displayed in a clearly visible location!



When pumping hot liquids, the pipes must be fitted with compensators to prevent tensions in the pump casing

There are various maximum temperatures for ROTAN pumps, depending on the pump type and the type of elastomer used, see Figure 21– Figure22.



ROTAN pumps may not be used to pump liquids at a temperature that is higher than the liquid's ignition temperature, and with reference to the maximum temperatures specified in the table in Figure 20 and no higher than the temperature in the table below – Figure 22 – depending on the type of elastomer used. For pumps with a by-pass valve the maximum temperature is 150°C/302°F.  
The lowest +temperature identified of the four mentioned above constitutes the maximum temperature.

The maximum liquid temperature for MD pumps also depends on the magnetic material used, see Figure 21.

The temperature of the liquid also increases during operation, through the heat generated by the magnets, depending on the liquid's flow rate and viscosity.

The temperature increases up to 30°C/86°F.



The MD pump may not be used to pump liquids at a temperature that is higher than the liquid's ignition temperature, and with reference to the maximum temperatures specified in the table in Figure 21 depending on the magnetic material, and no higher than the temperature stated in the table below – Figure 22 – depending on the type of elastomer used. For pumps with a by-pass valve the maximum temperature is 150°C/302°F.

The lowest +temperature identified of the four mentioned above constitutes the maximum temperature.

The maximum temperature limit identified must be further reduced by the temperature increase generated by the magnets.

Maximum liquid temperature		
Pump type	Temperature in celsius	Temperature in fahrenheit
GP	Maximum 150°C	Maximum 302°F
HD/PD/CD*	Maximum 250°C	Maximum 482°F
MD	Maximum 130°C (Magnetic material: Neodymium-Iron-Boron)	Maximum 266°F (Magnetic material: Neodymium-Iron-Boron)
	Maximum 250°C (Magnetic material: Samarium Cobalt)	Maximum 482°F (Magnetic material: Samarium Cobalt)
CC	Maximum 80°C	Maximum 176°F

Figure 21 The pump liquid's maximum permitted temperature for the various pump types shown in Celsius and Fahrenheit. For pumps with a by-pass valve the temperature is limited to a maximum of 150°C/302°F due to the valve key. However, the valve can be supplied with a different key, enabling the pump's temperature range to be fully utilized. The MD pump's maximum temperature depends on factors such as the magnetic material.

\*Pump types HD, CD and PD – produced in versions with special tolerances – can in some cases be used up to 300°C/572°F.

Minimum/maximum elastomer temperature			
Elastomer type	Elastomer brand	Temperature in celsius	Temperature in fahrenheit
FPM	Viton®	Approx. -25°C/+170°C*	Approx. -13°F/+338°F*
FEP	Teflon® with Viton core	Approx. -60°C/+205°C	Approx. -76°F/+401°F
EPDM	Ethylene-propylene	Approx. -65°C/+120°C	Approx. -85°F/+248°F
FFKM	Kalrez®	Approx. -50°C/+316°C	Approx. -58°F/+600°F
NBR	Nitril	Approx. -30°C/+70°C	Approx. -22°F/+158°F
PTFE	Teflon	Approx. -15°C/+170°C	Approx. -5°F/+338°F

Figure 22: The pump liquid's minimum/maximum temperature limits for the various elastomers used in ROTAN pumps.

\*Maximum 135°C/275°F in water.



Extra shielding may be purchased from DESMI

## Foods



ROTAN pumps must **not** be used to pump foods requiring FDA or 3A approval

## Noise

The noise level of ROTAN pumps depends on various parameters. The different parameters that can influence the sound pressure level are: differential pressure, viscosity, installation conditions, pump size and flow.

The curves shown in Figure 23 denote standard units with ROTAN pumps' A-weighted sound pressure levels, in relation to pump size and flow.

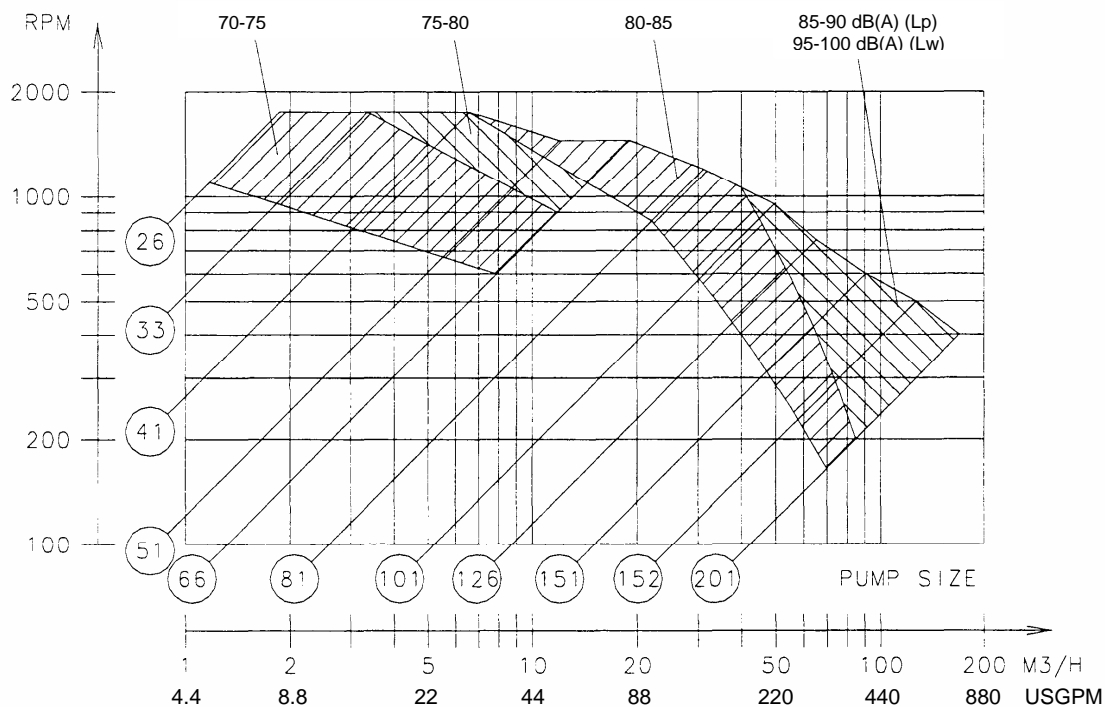

Figure 23: The maximum A-weighted sound pressure level in dB(A) (Lp) for the various pump sizes in relation to the

pumps' flow. The range above 85 dB(A) is also expressed as sound power level (Lw).

The sound pressure curves shown are measured at a distance of 1 metre/3.1 feet from the pump's surface and at a height of 1,60 metres/5,2 feet above the floor. The dB(A) curves shown are calculated on the basis of measurements taken when pumping mineral oil with a viscosity of 75 cSt/4,54 SSU at a differential pressure of 5 bar/72.5 psi. The curves are based on normal industrial use, and not on laboratory conditions.

If people are working by the pump, we refer to the prevailing local national laws and regulations on noise limits at the workplace.

We refer to the prevailing local national laws and regulations on noise limits at the workplace.

Appropriate noise reduction measures must be implemented in accordance with the aforementioned local national laws and regulations, if so required.



Use appropriate hearing protection if necessary!

If necessary, display a sign stating that hearing protection must be worn!

## Storing the user manual

This user manual must be retained throughout the pump's full service life, and must always accompany the pump.

The user manual must be available to operators, repair engineers and any maintenance staff or other people who may be considered to have a need to refer to it.

The user manual must also be stored visible, in the immediate vicinity of the pump.

If this is not possible, there must be a prominent sign by the pump stating where the user manual is kept.

It is also recommended that a copy of the user manual is stored somewhere else.

If people who are expected to have a need to refer to the user manual are of a different linguistic origin than the language in which the user manual has been legally supplied, it is recommended that the user manual is translated into the language in question.

## Maintenance

The pump must be inspected and maintained on an ongoing basis in accordance with the schedule below – Figure 24.

Compliance with regular maintenance in accordance with the schedule below is particularly important for explosion-proof pumps (ATEX), as inspection and maintenance of the pump constitutes a part of the explosion protection.



Observe the inspection and maintenance instructions contained in this manual to achieve explosion protection for EEx-labeled pumps.

Maintenance	
<b>During daily inspection, check:</b>	
That the pump does not vibrate or emit jarring sounds	
That lubricated slide bearings are lubricated	
That open ball bearings are lubricated	
That any lubricating devices are in working order	
That any circulation pipes – cooling, heating or pressurized water pipes are in working order	
That power output and power consumption are correct	
That the operating pressure is correct	
<b>During weekly inspection, check:</b>	
That any filters and drainage holes are clean	
That the areas around the stuffing box and the bearings are free of dust	
That the soft stuffing box is leaking 10-100 drops per minute	
Whether flexible connecting elements are worn	Replace if worn
That mechanical shaft seals are not leaking	
<b>During inspection every 2 months, check:</b>	
That the bearings do not have too much play	
That the by-pass valve (if fitted) opens at the correct pressure	
That the by-pass valve (if fitted) is in working order	

Figure24: The figure shows which parts or what must be checked and maintained on the pump, and at what intervals this must be undertaken.

## Adjusting the soft shaft seal



The shaft seal must not be adjusted during operation.

It is important that the soft shaft seal leaks during operation, as this provides lubrication and also releases the frictional heat that is generated.

The shaft seal with packing rings requires continuous adjustment, to make sure that the volume of leakage by the stuffing box is correct.

Depending on the speed, pressure, pump size and viscosity, the stuffing box must leak 10-100 drops per minute to remove the frictional heat that is generated between the shaft and the packing rings. If there is insufficient leakage, the heat generated can cause the gasket rings to harden and create increased wear on the shaft.

The leakage described above is achieved by tightening the packing rings axially, so that they apply a pressure against the shaft. This pressure restricts the flow of the liquid, as the play between the shaft and the packing ring is in the order of a few thousandths of a millimeter.

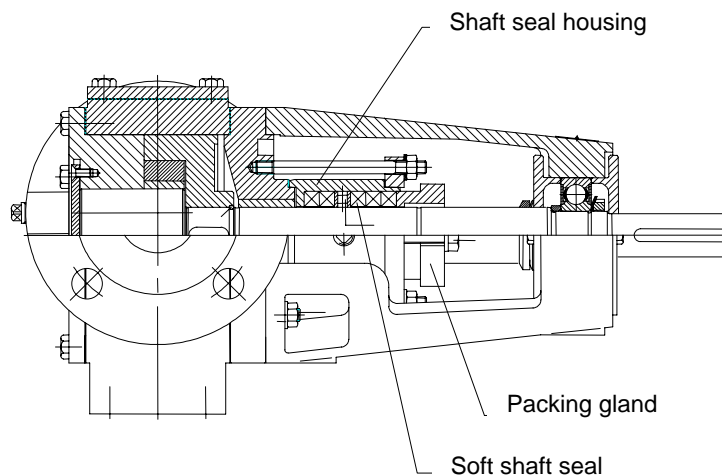

Figure 25: The location of the soft shaft seal, the shaft seal housing and the packing gland on the pump. The design of the shaft seal housing, does, however, depend on the individual pump application.

### 17.1.1. Repacking – soft shaft seal

1. Pull the packing gland back on the shaft once the screws have been removed.
2. The packing rings can now be pulled out using a packing extractor.
3. Check the shaft and the shaft seal housing thoroughly for wear, scratches and deposits.
4. Replace worn parts and remove deposits with care.
5. Always conduct a control measurement of the shaft and the shaft seal housing before specifying the packing dimension.

!! Never use old packing rings when measuring

The packing dimension is defined on the basis of the following:

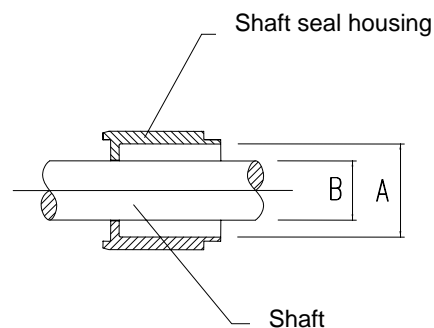

Figure 26: The A and B dimensions on the shaft and the shaft seal housing

The A and B dimensions obtained are inserted in the following formula to determine the packing dimension.

$$\frac{A - B}{2} = \text{packing dimension}$$

6. New packing rings are bought as spare parts or produced as described in step 7.
7. Trim the new packing rings on the shaft or a mandrel of the same diameter as the shaft.  
Wrap the packing around the shaft/mandrel the number of times that packing rings are to be used, and cut through with a sharp knife.

8. If the packing rings are difficult to move into position, they can be rolled with a pipe or similar item.  
Never strike a gasket, as the fibers in the material will be destroyed and the sealing property will be significantly worsened.
9. Lubricate the individual rings with a little oil to facilitate installation.
10. Turn the ring openings so that the two rings lying alongside one another are diametrically offset.
11. Finally, tighten the packing gland gently by hand, and restart the pump.

### Ball bearings

The pump is fitted with a ball bearing – pos. CU – at the pump's free shaft end.  
Some pumps are fitted with two ball bearings – pos. CU + BC – see the position numbers on the spare part drawings.

MD pumps are fitted with two ball bearings – pos. NB – on pumps with a free shaft end.

All bearings are model 63 deep-groove ball bearings, fitted with two rubber seal rings, no seal rings or one single seal ring.

#### 17.2.1 Lubricating ball bearings



Ball bearings must be lubricated to ensure explosion protection.



Ball bearings must be lubricated with heat-resistant grease when pumping liquids over 100°C/212°F – to guarantee explosion protection.



Ball bearings must be lubricated with heat-resistant grease when pumping liquids over 100°C/212°F.

Ball bearings with two seal rings do not require re-lubrication, as they are filled with a suitable amount of grease in the factory.





Service life of ball bearings in ROTAN pumps @ 1000 cSt						
Pump type	Pump size	Ball bearing type	Min. service life in hours at 70°C / 158°F	Max. operating pressure in bar	Max. operating pressure in psi	
GP	26 / 33	6302 2RS1	10,000 hours	16 bar	232 psi	
		6304 2RS1	27,000 hours			
	41	6304 2RS1	12,000 hours			
		6305 2RS1	18,000 hours			
	51 / 66	6306 2RS1	8,000 hours			
		6307 2RS1	8,000 hours			
	HD	81	6308 2RS1			7,000 hours
			6310 2RS1			9,000 hours
	PD	101	6308 2RS1			25,000 hours
			6310 2RS1			36,000 hours
	CD	126	6310 2RS1			30,000 hours
			6312 2RS1			32,000 hours
151		6310 2RS1	12,000 hours			
		6312 2RS1	11,000 hours			
152		6310 2RS1	4,000 hours			
		6314 2RS1	5,000 hours			
	6312 2RS1	9,000 hours				
201	6315 2RS1	8,000 hours	10 bar	145 psi		

Figure 28: Ball bearing types and the minimum service life in hours for the various pump types and sizes.

The service life is calculated on the basis of a temperature of 70°C/158°F and a viscosity of 1000 cSt./4600 SSU, and based on the maximum operating pressure of the various pump types.

The bearings' service life is reduced at temperatures above 70°C/158°F and in ATEX pumps – see section above.

Service life of ball bearings in ROTAN high-pressure pumps @ 1000 cSt/ 4600 SSU					
Pump type	Pump size	Ball bearing type	Min. service life in hours at 70°C/158°F	Max. operating pressure in bar	Max. operating pressure in psi
GP	27 / 34	6304 2RS1	12,000 hours	25 bar	362 psi
	42	6305 2RS1	13,000 hours		
	52 / 67	6307 2RS1	8,000 hours		
	82	6310 2RS1	8,000 hours		

Figure 29: Ball bearing types and the minimum service life in hours for pump type GP in the sizes indicated. The service life is calculated on the basis of a temperature of 70°C/158°F and a viscosity of 1000 cSt/ 4600 SSU, and based on the maximum operating pressure of ROTAN high-pressure pumps. The bearings' service life is reduced at temperatures above 70°C/158°F and in ATEX pumps – see above.

### Lubricating slide bearings



Slide bearings must be lubricated to guarantee explosion protection.



Slide bearings must be lubricated with heat-resistant grease when pumping liquids over 100°C/212°F – to guarantee explosion protection.



Slide bearings must be lubricated with heat-resistant grease when pumping liquids over 100°C/212°F.

The ROTAN pump is designed with a idler bearing and a main bearing.

The idler bearing is a slide bearing, and the main bearing can be either a slide bearing or a ball bearing.

The table below shows what the various pump types are equipped with.

The position numbers refer to the section entitled “Spare parts drawings”.

<b><u>Type HD:</u></b>	Idler bearing* pos. AD/main bearing pos. BC Main bearing = slide bearing
<b><u>Types CD, PD:</u></b>	Idler bearing pos. AD/main bearing pos. BC Main bearing = slide bearing
<b><u>Type GP:</u></b>	Idler bearing* pos. AD/main bearing Main bearing = soft shaft seal or ball bearing
<b><u>Type MD:</u></b>	Idler bearing pos. AD/main bearing pos. PS Main bearing = slide bearing
<b><u>Type CC:</u></b>	Idler bearing pos. AD Main bearing = none

\* The idler bearing is, however, not fitted to pump sizes 26 + 33, where the idler is made of bronze or cast iron. The idler is instead fitted with a plate, so that the idler/idler pin can be lubricated.

If the pump liquid itself has a lubricating effect or is of sufficiently high viscosity, the bearings are lubricated by the pump liquid – otherwise the bearings must be lubricated via the lubrication nipple.

If the pump is supplied with a idler bearing and a main bearing for external lubrication, the pump designation will include an “**M**” – see the pump’s name plate! – if not, there is a “**U**” in the place indicated.

Example: HD51BCHD-1**M**22BS

The bearings must be lubricated in accordance with the table in Figure 31, but the re-lubrication intervals and grease volumes are only guidelines, as the re-lubrication interval in particular is largely dependant on the conditions.

Obtain further information from the supplier.

The bearings must be lubricated with Rubens WB Q8 or equivalent.

Lubrication of slide bearings					
Pumpe type: HD, GP, CD, PD, MD, CC	Re-lubrication interval in hours	Amount of grease in grams		Amount of grease in ounce	
		Main bearing (grams)	Idler bearing (grams)	Main bearing (ounce)	Idler bearing (ounce)
26	8 hours	1	1	0.04	0.04
33		1	1	0.04	0.04
41		1	1	0.04	0.04
51		1.5	1.5	0.05	0.05
66		1.5	1.5	0.05	0.05
81		2	2	0.07	0.07
101		2	2.5	0.07	0.09
126		2.5	4	0.09	0.14
151		2.5	6	0.09	0.21
152		4	10	0.14	0.35
201		8	14	0.28	0.49

Figure 30: Re-lubrication intervals and amounts of grease in grams/ounce for lubrication of slide bearings – main bearing and idler bearing.

## Troubleshooting

<b>Problem:</b>								
<b>8. Lack of co-ordination between pressure and canisteracity</b>								
<b>7. The pump cannot self-prime</b>								
<b>6. The pump loses liquid after self-priming</b>								
<b>5. The canisteracity is too low</b>								
<b>4. The pump is making a noise</b>								
<b>3. The motor is overloaded</b>								
<b>2. The pump has jammed</b>								
<b>1. The pump wears quickly</b>								
<b>Cause:</b>	<b>1</b>	<b>2</b>	<b>3</b>	<b>4</b>	<b>5</b>	<b>6</b>	<b>7</b>	<b>8</b>
1. Too great a vacuum				X	X	X	X	
2. Cavitation				X	X	X		
3. Viscosity too high			X	X	X		X	X
4. Temperature too high		X	X				X	
5. The pump is drawing air				X	X	X	X	X
6. Pressure too high	X	X	X		X			
7. Defective valve			X	X	X			
8. The pump is corroded	X				X		X	
9. The pump is worn					X		X	
10. Impurities in the pump	X	X	X					
11. The stuffing box is over-tightened*	X		X					
12. Fault in the motor			X					
13. Pipe too constricted or blocked					X		X	
14. Wrong speed							X	
15. The pump runs without liquid	X	X					X	
16. Liquid temp. too high – lack of lubricant	X	X						
17. Speed too low					X			
18. Speed too high				X				X
19. Suction line not dipped in liquid							X	
20. Liquid being fed above liquid level				X				
21. Valve incorrectly adjusted					X			
22. The pump's shaft end is bent	X			X				
23. Coupling incorrectly aligned	X			X				
24. Pump twisted in relation to pipe system	X	X	X	X				
25. Leaking pipes/assemblies							X	

Figure 31: Various problems that can arise and possible causes of the problems.

\*Point 11 does not apply for pump type MD.

Because of the ROTAN pump's large number of possible combinations and the many pump liquids used, it is not possible to provide instructions on the rectification of the problems in this manual.

If the pump has been bought in Denmark, we therefore refer to DESMI's service centers at the back of this manual. If the pump was bought outside Denmark, we refer to the relevant agent – look at the back of this manual.

## Emptying and cleaning the pump

If the liquid being pumped is inflammable, toxic, corrosive or hazardous in any other way, or if the liquid has a temperature of more than 60°C/140°F, special safety measures must be implemented before the pump is emptied.

The liquid's safety data sheet must be obtained and read before emptying the pump.

Please refer to the relevant liquid's safety data sheet.



Observe the safety instructions in the data sheet for the liquid in question and use the specified safety equipment in the form of protective clothing, a breathing mask or similar necessary safety equipment.



Use suitable safety equipment with pump liquids at temperatures of more than +60°C/140°F.



When pumping hazardous liquids, circulate neutralizing liquid before emptying the pump.



The system must be depressurized before emptying the pump.



Use spark-free tools when removing the front cover/dismantling the pump in potentially explosive atmospheres.



1. When pumping hazardous liquids, circulate a liquid that has a neutralizing effect in relation to the pump liquid.  
We recommend the use of thin neutralizing liquids to facilitate drainage.
2. Empty the pipe system.

Note that there is still liquid in the bottom of the pump casing and in the shaft seal housing, even if the pipe system is empty, and in the case of the MD pump there will also be liquid in the magnetic coupling's canister.

3. Stop the unit.
4. Close the valves on the suction side and the pressure side, if the system is equipped with these, so that the system is un-pressurized.
5. Place a collecting tank under the pump to take the volume of liquid contained in the part of the system to be emptied.
6. Remove the front cover and the heating jacket.
7. Remove the pump and place it with the ports pointing up/down, and then rotate the shaft manually to empty.

Please note that the drainage time is longer for highly-viscous liquids, as these find it difficult to make their way from the stuffing box house through the chamber between the rotor and the rear cover to the pump casing.

Some special versions of the pump are fitted with one or more draining plugs, to facilitate the drainage of highly-viscous liquids.

## **Removal of liquid**

The safety data sheet for the liquid used must be obtained, and the liquid must be removed in accordance with the safety data sheet's instructions.

Please refer to the relevant liquid's safety data sheet!



The safety instructions in the data sheet for the liquid in question must be observed, and the safety equipment specified must be used.

## Repairs

**ATEX**

Use spark-free tools when assembling and dismantling the pump and pump parts in potentially explosive atmospheres.

**Pumps that are sent to DESMI for repair must have been emptied and cleaned before our factory can accept them, and the pumps must be accompanied by information about the pump liquid used.**

Cleaning and emptying of the pump must be undertaken with due regard to the safety of our repair engineers.

We would like to point out that certain liquids coagulate and harden before arrival at our factory, which makes any repairs fully or partly impossible if the pump has not been emptied and cleaned before shipment.

In such cases, inadequate emptying and cleaning will generate increased repair costs, or in the worst case mean that the pump has to be scrapped.

ROTAN pumps must be emptied and cleaned in accordance with the instructions in the section entitled “Emptying and cleaning the pump” – please read it!

## Setting of temperature sensor

If the temperature sensor has been dismantled during repair it has to be set again when reassembling the pump.

1. Apply heat-conducting paste to the tip of the sensor in order to secure good heat transmission
2. Screw in the sensor till the bottom is reached
3. Now unscrew the sensor approx. ¼ of a turn

## Axial clearance

The axial clearance is the distance between the rotor/idler and the front cover.

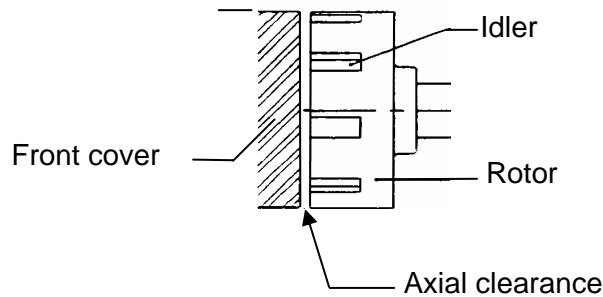

Figure 32: The axial clearance between the rotor/idler and the front cover.

The axial clearance is set in the factory in accordance with the section entitled “Setting the axial clearance”.

The axial clearance must be reset after the pump has been repaired or if the pump is worn.

There are various ways of setting the axial clearance, depending on the pump type and whether or not the pump is installed in a pipe system. See the section entitled “Setting the axial clearance”.

### 21.1.1 Checking the axial clearance

The axial clearance can be checked as described below:

#### **Non-installed pump:**

The pump’s axial clearance can be checked with an air gap gauge, which is passed in through one of the pump’s ports between the rotor/idler and the front cover.

The axial clearance identified must correspond to the values in the table in Figure 34.

#### **Installed pump:**

The axial clearance cannot be checked when the pump is installed in a pipe system.

The play must therefore be reset as described in the section entitled “Setting the axial clearance”.

Axial clearance in mm/inches									
Pump size	Unit		26/33	41	51/66	81/101	126/151	152	201
Normal axial clearance*	mm.	Min.	0.10	0.10	0.15	0.20	0.30	0.35	0.40
		Max.	0.125	0.15	0.20	0.25	0.375	0.45	0.50
Pumps with spec. tolerances**	mm.	Min.	0.20	0.20	0.30	0.40	0.60	0.70	0.80
		Max.	0.25	0.30	0.40	0.50	0.75	0.90	1.0
Normal axial clearance*	inches	Min.	0.0039	0.0039	0.0059	0.0079	0.0118	0.0138	0.0157
		Max.	0.0049	0.0059	0.0079	0.0098	0.0148	0.0177	0.0197
Pumps with spec. tolerances**	inches	Min.	0.0079	0.0079	0.0118	0.0157	0.0236	0.0276	0.0315
		Max.	0.0098	0.0118	0.0157	0.0197	0.0295	0.0354	0.0394
Stainless pumps*	-	Add 0.10 mm/0.004 inches to the above values							

Figure 33: The axial clearance in mm/inches for the various pump sizes for standard pumps and pumps with special tolerances respectively. This table applies to pump types HD, CD, PD, GP, CC and MD.

\* Pumps made of stainless steel are set with 0.10 mm/0.004 inches more clearance than specified. Pumps of stainless steel are identified by the number “3” in the pump designation. Viz. CD26EFMDK-3U332.

\*\* Pumps with special tolerances are identified by the inclusion of a “T” or “CHD” in the designation. Example: HD/CD41EF-CHD-1M22B or GP101ED-T-1U22B – see also section entitled

## 21.1.2 Setting the axial clearance

The axial clearance is set by means of:

- Types HD, CD, PD:** Adjusting screws pos. CT/bearing covers pos. CS/CR
- Type GP:** Adjusting screws pos. KX/KY/muff coupling pos. DB
- Type MD:** Adjusting screws pos. E/NM/front cover pos. AA
- Type CC:** Adjusting screws pos. E/NM/front cover pos. AA or  
Adjusting screws pos. E/front cover pos. AA/shim ring(s)  
pos. AS

See the position numbers in the section “Spare parts drawings”/“Spare parts list”.

In the case of pumps installed in a pipe system, the axial clearance is set by turning the pump’s adjusting screws to a given angle (see below table for calculation of the angle).

Pump type		Min./max. angle change in degrees of the adjusting screws									
		26/33	41	51/66	81/101	126	151	152	201		
Clearance		Angle change in degrees									
HD (cast iron)	Standard	Min.	45°	36°	54°	58°	86°	86°	86°	84°	82°
	Special tolerances*	Max.	56°	54°	72°	72°	108°	108°	108°	108°	103°
PD (steel)	Standard	Min.	90°	72°	108°	115°	173°	173°	173°	168°	165°
	Special tolerances*	Max.	113°	108°	144°	144°	216°	216°	216°	216°	206°
CD (stainless steel)	Standard	Min.	90°	72°	90°	88°	115°	115°	115°	108°	103°
	Special tolerances*	Max.	101°	90°	108°	101°	137°	137°	137°	132°	123°
GP (cast iron)	Standard	Min.	90°	72°	108°	115°	173°	173°	173°	168°	165°
	Special tolerances*	Max.	113°	108°	144°	144°	216°	216°	216°	216°	206°
MD (cast iron/steel)	Standard	Min.	36°	29°	43°	58°	72°	72°	72°	72°	
	Special tolerances*	Max.	45°	43°	58°	72°	90°	90°	90°		
MD (stainless steel)	Standard	Min.	72°	58°	86°	115°	144°	144°	144°	144°	
	Special tolerances*	Max.	90°	86°	115°	144°	180°	180°	180°	180°	
CC (cast iron)	Standard	Min.	72°	72°	72°	86°	96°	96°	96°		
	Special tolerances*	Max.	81°	90°	86°	101°	114°	114°	114°		
CC (cast iron)	Standard	Min.	72°	72°	86°	115°	144°	144°	144°		
	Special tolerances*	Max.	90°	108°	115°	144°	180°	180°	180°		
CC (cast iron)	Standard	Min.	36°	36°							
	Special tolerances*	Max.	45°	54°							
CC (cast iron)	Standard	Min.	72°	72°							
	Special tolerances*	Max.	90°	108°							

Figure 34: Shows the min./max. angle change in degrees - when setting the axial clearance - for the shown pump types in the stated materials and executions.

\* Pumps with special tolerances are characterized in that a "T" or a "CHD" is part of the designation.

Example: HD/CD41EF **CHD**-1M22B or GP101ED**T**-1U22B - see the chapter "Pump executions"

The setting screws of the pump should be turned in pairs to the angle found above (see figure xx) in order to secure straight mounting. The angle size of the adjusting screws appears from figure xx.

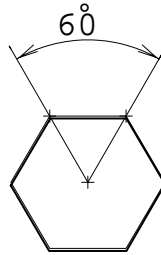

Figure 36: Shows the angle size for a single surface on the hexagonal bolt head on the adjusting screw.

The procedure for adjusting the axial clearance of the various pump types - goes for both installed and non-installed pumps - appears from figure xx.

## Setting the axial clearance

Non-installed pump:	Installed pump:
<p><b>Types HD, CD, PD:</b></p> <ol style="list-style-type: none"> <li>Loosen bearing covers pos. CS/CR, so that the shaft can be pushed axially.</li> <li>The pump's axial clearance is obtained from the table in Figure 34.</li> <li>Insert an air gap gauge between the front cover and the rotor/idler.</li> <li>Push the shaft towards the front cover until the air gap gauge becomes jammed.</li> <li>Tighten the bolts in pairs, so that the bearing covers do not force the ball bearing to one side.</li> <li>When adjustment is complete, make sure that the pump shaft turns easily and regularly, and that no jarring noises can be heard.</li> </ol>	<p><b>Types HD, CD, PD:</b></p> <ol style="list-style-type: none"> <li>Loosen bearing cover pos. CS.</li> <li>Tighten bearing cover pos. CR.</li> <li>Loosen bearing cover pos. CR in accordance with the number of degrees obtained in the formula – Figure 36.</li> <li>Tighten bearing cover pos. CS.</li> <li>Tighten the bolts in pairs, so that the bearing covers do not force the ball bearing to one side.</li> <li>When adjustment is complete, make sure that the pump shaft turns easily and regularly, and that no jarring noises can be heard.</li> </ol>
<p><b>Type CC (with shim rings):</b></p> <ol style="list-style-type: none"> <li>Remove set screws pos. E.</li> <li>Remove front cover pos. AA.</li> <li>Remove shim ring(s) pos. AS.</li> <li>Loosely attach front cover and set screws.</li> <li>The pump's axial clearance can be seen in the table in Figure 34: _____</li> <li>Insert an air gap gauge between the front cover and the rotor/idler.</li> <li>Tighten the front cover until the air gap gauge becomes jammed.</li> <li>Measure the distance between the pump casing pos. A and the front cover pos. AA: _____</li> <li>The figure obtained is the thickness of the new shim ring.</li> <li>Obtain the shim ring(s) pos. AS and fit as described above.</li> <li>When adjustment is complete, make sure that the pump shaft turns easily and regularly, and that no jarring noises can be heard.</li> </ol>	<p><b>Type CC (with shim rings):</b></p> <ol style="list-style-type: none"> <li>Remove set screws pos. E.</li> <li>Remove front cover pos. AA.</li> <li>Remove shim ring(s) pos. AS.</li> <li>Re-attach the front cover and set screws, and screw the front cover to the idler.</li> <li>Check that the pump shaft <i>cannot</i> turn. (If the pump shaft can turn, this is because the front cover and/or rotor/idler are worn, and the play can thus not be set correctly. Worn items must then be replaced before resetting the axial clearance.)</li> <li>Measure the distance between the pump casing pos. A and the front cover pos. AA: _____</li> <li>The pump's axial clearance can be seen in the table in Figure 34: _____</li> <li>The two figures obtained together define the thickness of the new shim ring: _____</li> <li>Obtain the shim ring(s) pos. AS and fit as described above.</li> <li>When adjustment is complete, make sure that the pump shaft turns easily and regularly, and that no jarring noises can be heard.</li> </ol>

**Non-installed/installed pump:****Type MD, CC (with set screws):**

1. Loosen set screws pos. NM.
2. Tighten adjusting screws pos. E until the front cover is positioned against the rotor/idler.
3. Check that the pump shaft *cannot* turn.
4. (If the pump shaft can turn, this is because the front cover and/or rotor/idler are worn, and the play can thus not be set correctly. Worn items must then be replaced before resetting the axial clearance.)
5. Loosen adjusting screws pos. E according to the no. of degrees obtained in the formula – Figure 36.
6. Tighten set screws pos. NM.
7. In non-installed pumps, once adjusted the play must be checked with an air gap gauge in at least 3 different points, to ensure that the front cover is parallel with the rotor.
8. Finally, make sure that the pump shaft can turn easily and regularly and that no jarring sound can be heard.

**Type GP:**

1. Loosen set screw pos. DC on muff coupling pos. DB
2. Loosen the short set screws pos. KY.
3. Tighten the long set screws pos. KX until the rotor is positioned against the front cover.
4. Loosen the long set screws pos. KX according to the no. of degrees obtained in the formula – Figure 36.
5. Tighten the short set screws pos. KY.
6. Tighten set screw pos. DC.
7. When adjustment is complete, make sure that the pump shaft turns easily and regularly, and that no jarring noises can be heard.  
(The flange motor in GP pumps must have a locked bearing at the end of the shaft end, to ensure that the pump's axial clearance falls within permitted parameters.)

Figure 37: The procedure for setting the axial clearance in the various pumps for installed and non-installed pumps respectively.

## Spare parts

We recommend that you use original spare parts.

DESMI accepts no liability for any personal injury or damage to the pump as a consequence of the use of non-original spare parts that do not satisfy precisely the same strict quality requirements as original DESMI spare parts.

## Ordering spare parts

When ordering spare parts, the following information must be provided:

- The pump's serial number	252756
- The pump's SX no.	5310
- The pump type	HD81ERM-1U332
- If relevant, the code of the mechanical shaft seal	AD
- If relevant, the number of the magnetic coupling	-
- If relevant, the number of the by-pass valve	-
- The spare part's position designation	Pos. CJ
- The spare part's designation	Mechanical shaft seal

The above information may be found on the pump's name plate – Figure 39  
The serial number is also embossed on the pump's left port.

<b>ROTAN® PUMP</b>			
HD81EMR		1U2B2	
SX	6120	NO	253016
VALVE	6144	SEAL	CB
DESMI INC. 2551 Eltham Ave Norfolk, Virginia 23513			
<b>MADE IN DENMARK</b>			

Figure 38: An example of a pump's name plate.

## Spare parts drawings

This section contains a representative selection of ROTAN sectional drawings. Not all pump configurations are included, but taken together the drawings selected show the most common position designations and designs.

HD..EDK  
(GP..E)  
(HD..ECHD)

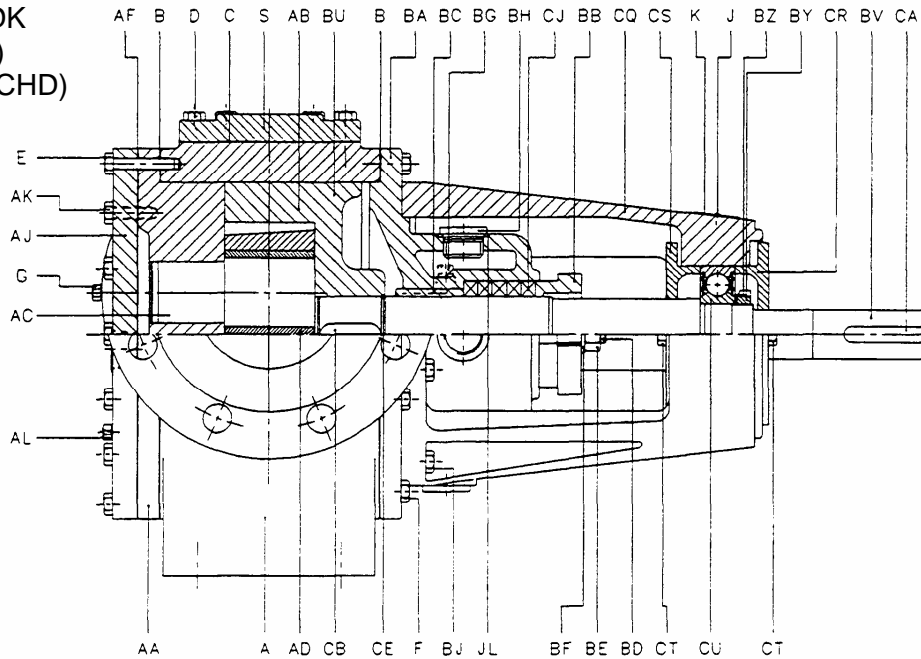

CHD

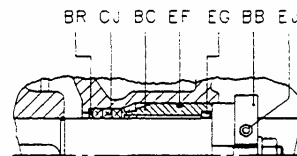

GP..EM  
(HD..EM)

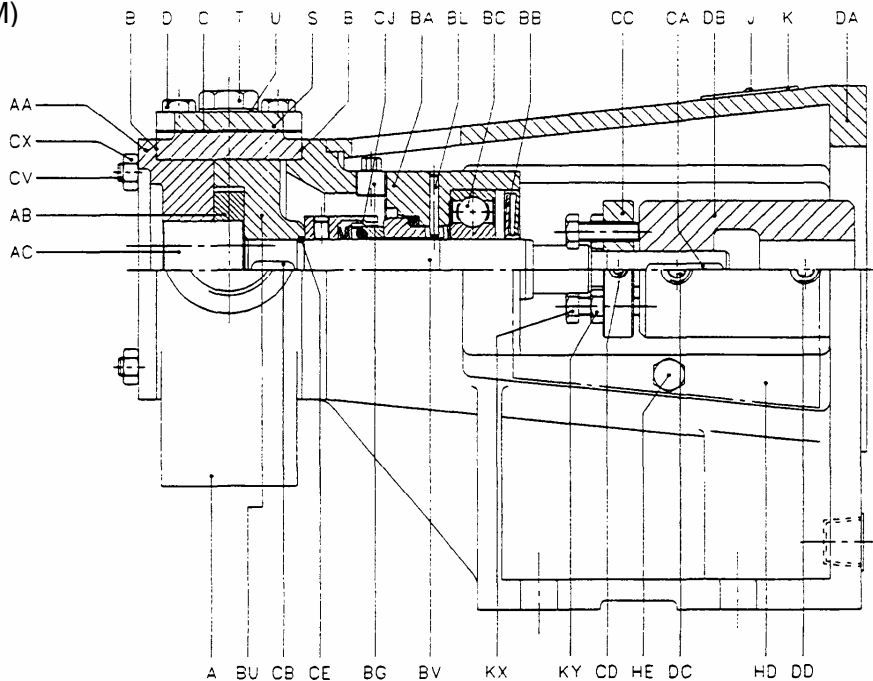

HD..EM

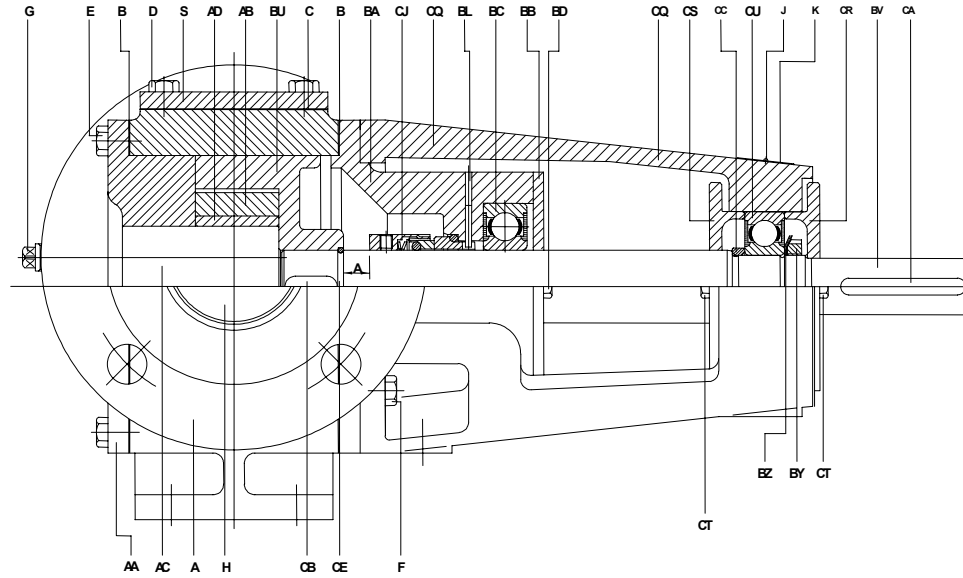

CD/PD..EFDKMMW – (CD/PD..EFMM) – (CD/PD..EFMMP)

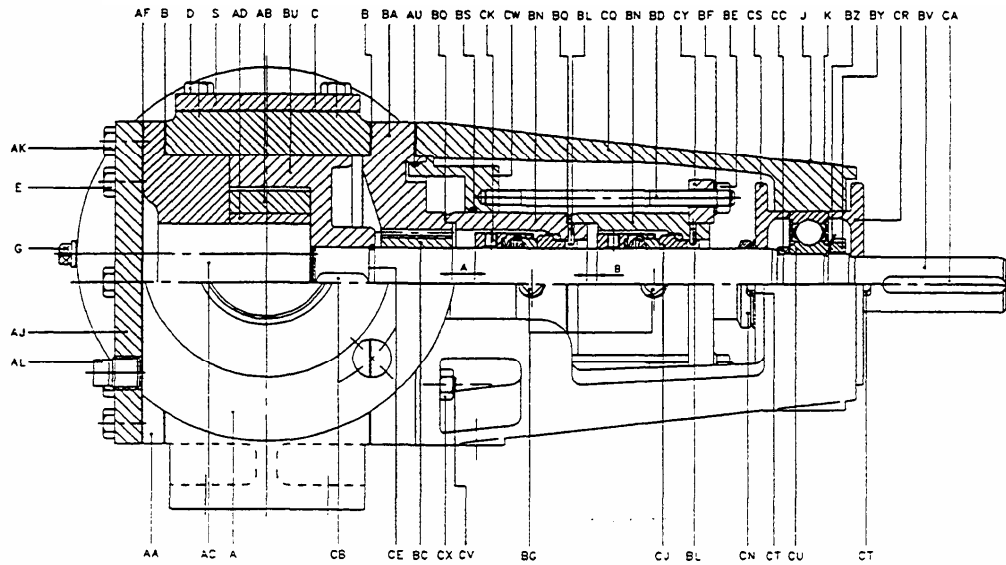

MM

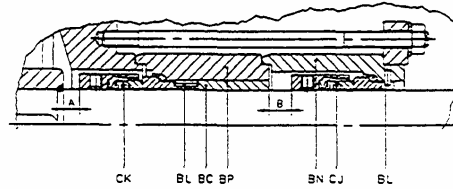

MMP

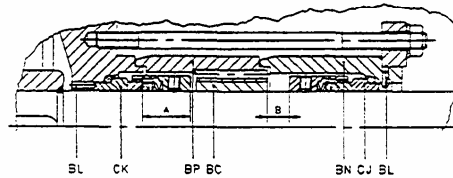

## CD/PD..EF

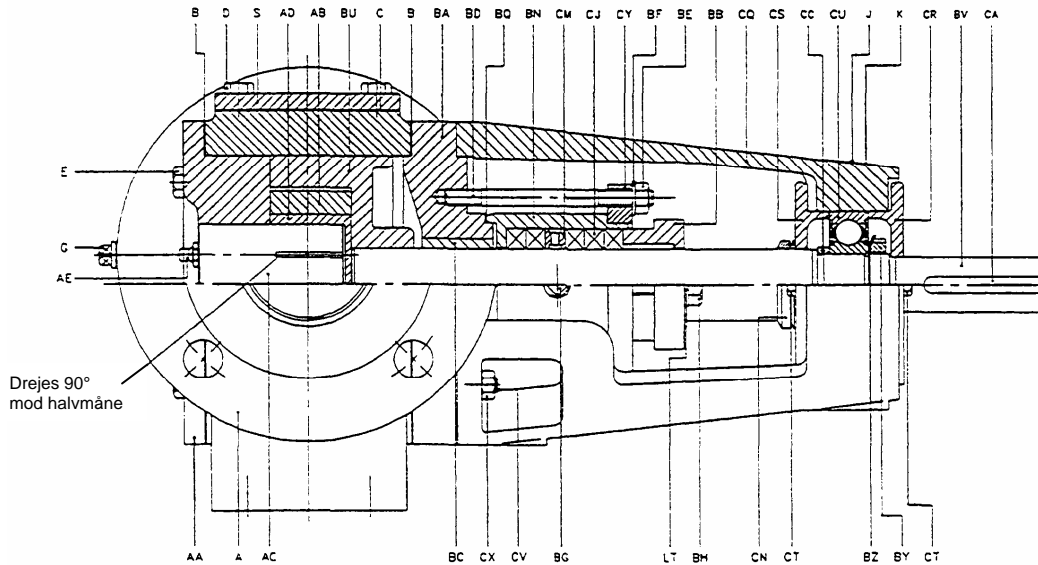

## MD..EFDK

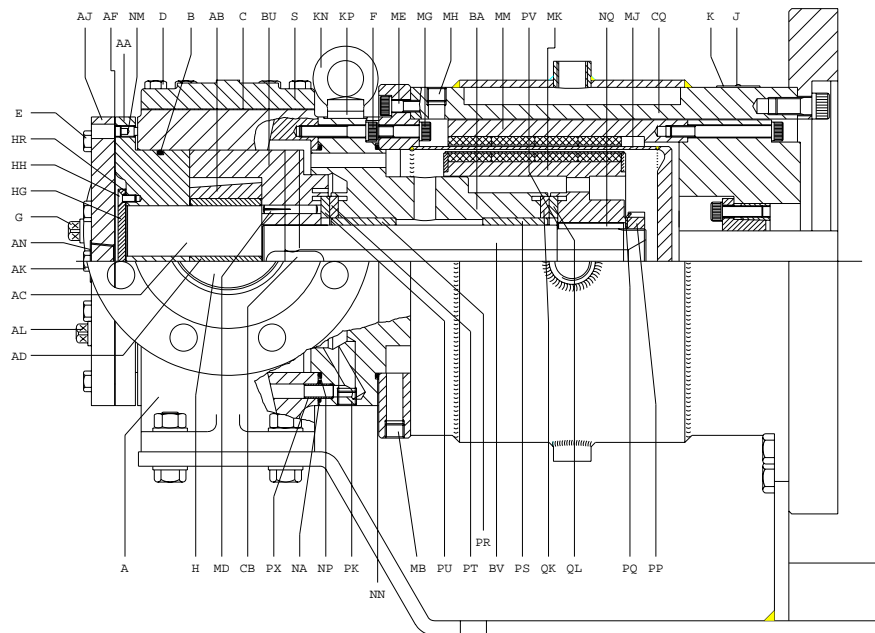

By-pass valve for HD, GP (CD, PD, MD).

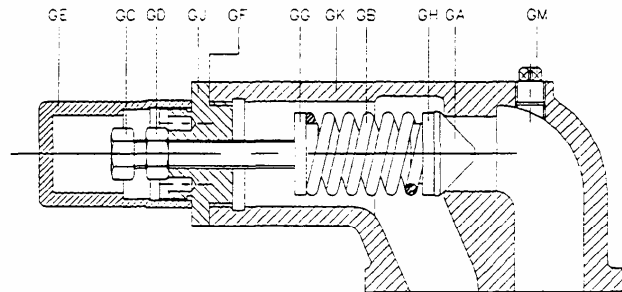

**Spare parts list**

<b><u>Pos.</u></b>	<b><u>Designation</u></b>	<b><u>Pos.</u></b>	<b><u>Designation</u></b>
A	Pump casing	BH	Bolt/pipe plug
B	Gasket/O-ring	BJ	Bolt
C	Gasket	BL	Priming pin
D	Bolt	BN	Shaft seal housing
E	Bolt	BP	Intermediate bearing
F	Bolt	BQ	Gasket
G	Pipe plug	BR	Spacer ring
J	Drive screw	BS	O-ring
K	Nameplate	BU	Rotor
S	Blind cover	BV	Shaft
T	Pipe plug	BY	Ball bearing nut
U	Gasket	BZ	Ball bearing lock ring
AA	Front cover	CA	Key
AB	Idler	CB	Key
AC	Idler pin	CC	Fixing ring/spacer ring
AD	Idler bush	CD	Threaded screw
AE	Lubrication nipple/pipe plug	CE	Snap ring
AF	Gasket	CJ	Packing rings/mechanical shaft seal
AJ	Heating jacket	CK	Mechanical shaft seal
AK	Bolt	CM	Lantern ring
AL	Pipe plug	CN	V-ring
AU	O-ring	CQ	Bearing bracket
BA	Rear cover	CR	Bearing cover
BB	Packing gland/bearing cover	CS	Bearing cover
BC	Main bearing bush/ Ball bearing	CT	Bolt
BD	Stud bolt/bolt	CU	Ball bearing
BE	Nut	CV	Stud bolt
BF	Washer	CW	Heating jacket
BG	Pipe plug/lubrication nipple	CX	Nut

<u>Pos.</u>	<u>Designation</u>	<u>Pos.</u>	<u>Designation</u>
CY	Retaining flange	MF	Bolt
DA	Motor bracket	MG	Bolt
DB	Coupling	MJ	Canister
DC	Threaded screw	MK	Inner magnet
DD	Threaded screw	ML	Bolt
EF	O-ring	MM	Outer magnet
EG	Seal ring	MN	Washer
EJ	Bolt	MP	Bolt
GA	Valve	MQ	Bolt
GB	Key	MR	Lock ring
GC	Adjusting screw	MS	Key
GD	Nut	MT	Seal ring
GE	Canister	MU	Connecting flange
GF	Gasket	MV	Complete ball bearing
GG	Pressure plate	MW	Spacer ring
GH	Pressure plate	MX	Bolt
GJ	Valve cover	MY	Cylindrical pin
GK	Valve casing	MZ	O-ring
GM	Pipe plug	NA	O-ring
GN	Gasket	NB	Ball bearing
GQ	Bolt	NC	Temperature sensor
GR	Washer	ND	Bearing cover
HD	Shield	NE	Shaft
HE	Bolt	NF	Cover
JL	Gasket	NG	Disc spring
KX	Bolt	NJ	Bolt
KY	Bolt	NK	O-ring
LT	Washer	NM	Set screw
MA	O-ring	NN	O-ring
MB	Pipe plug	NP	O-ring
MC	O-ring	NQ	Key
MD	Roll pin	NS	Intermediate piece
ME	Bolt	NT	Thread fitting

**Pos. Designation**

NU	O-ring
NZ	Draining plug

**Technical specifications**

Because of the ROTAN pump's large number of possible combinations and the many pump liquids used, the following values should be viewed as guideline maximum values, as an individual ROTAN pump may have further limitations due to the pump liquid, the shaft seal selected and in particular the motor selected.

If the pump was bought outside Denmark, we refer to the relevant agent.

The technical specifications of the motor are contained in the manual supplied by the motor manufacturer.

**Capacity**

Pump type	Capacity in m <sup>3</sup> /h	Capacity in USGPM
GP	Maximum 50 m <sup>3</sup> /h	Maximum 183 USGPM
MD	Maximum 90 m <sup>3</sup> /h	Maximum 330 USGPM
HD/PD/CD	Maximum 170 m <sup>3</sup> /h	Maximum 623 USGPM
CC	Maximum 6,8 m <sup>3</sup> /h	Maximum 25 USGPM

Figure 39: The maximum capacity in m<sup>3</sup>/h / USGPM for the various pump types.

**Speed**

Pump size	Speed
26 / 33 / 41	Maximum 1,750 rpm
51 / 66	Maximum 1,450 rpm
81	Maximum 1,200 rpm
101	Maximum 950 rpm
126	Maximum 750 rpm
151	Maximum 600 rpm
152	Maximum 500 rpm
201	Maximum 400 rpm

Figure 40: The maximum speed in rpm for the various pump sizes – for pump liquids with a viscosity/Seybold Seconds Universal (SSU) of less than 400 cSt./1950 SSU. For higher viscosities/Seybold Seconds Universal (SSU) the speed should be reduced to avoid cavitation. This table is valid for all pump types: GP/HD/PD/CD/MD/CC.

### Operating pressure

Pump type/size	Operating pressure – pump casing in bar	Operating pressure – heat chamber in bar	Operating pressure – pump casing in psi	Operating pressure – heat chamber in psi
GP*/HD/PD/CD/MD 26 / 33 / 41 / 51 / 66 / 81	Maximum <b>16 bar</b> (maximum <b>25 bar*</b> )	Maximum <b>10 bar</b>	Maximum <b>250 psi</b> (maximum <b>362 psi*</b> )	Maximum <b>150 psi</b>
GP*/HD/PD/CD/MD 101 / 126 / 151 / 152 / 201	Maximum <b>10 bar</b> (maximum <b>25 bar*</b> )	Maximum <b>10 bar</b>	Maximum <b>150 psi</b> (maximum <b>362 psi*</b> )	Maximum <b>150 psi</b>
CC	Maximum <b>10 bar</b>		Maximum <b>150 psi</b>	

Figure 41: The maximum operating pressure in bar/psi for the various pump types. However, the maximum pressure stated depends on the delivery pressure to the pump and the pump size.

\* Pump type GP is also available in a special high-pressure version that can manage a maximum of 25 bar/362 psi, i.e. system pressure and differential pressure can **maximum** be 25 bar. The high-pressure version is available in pump sizes: 27 / 34 / 42 / 52 / 67 / 82. The pump size on the name plate will indicate whether the pump can manage a maximum of 25 bar/362 psi.

### Suction lift

Pump type	Suction lift in bar	Suction lift in psi
GP/HD/PD/CD/MD/CC	Maximum <b>0.5 bar</b> priming vacuum Maximum <b>0.8 bar</b> vacuum during operation	Maximum <b>7.3 psi</b> priming vacuum Maximum <b>11.6 psi</b> vacuum during operation

Figure 42: The maximum suction lift in bar/psi at priming vacuum and vacuum during operation respectively.

## Viscosity

Pump type	Viscosity in cSt	Seybold Seconds Universal (SSU)
GP	Maximum 7.500 cSt	Maximum 35.000 SSU
MD	Maximum 10.000 cSt	Maximum 46.000 SSU
HD/PD/CD	Maximum 75.000 cSt	Maximum 346.000 SSU
CC	Maximum 1.000 cSt	Maximum 4.600 SSU

Figure 43: The pump liquid's maximum permitted viscosity in cSt/Seybold Seconds Universal (SSU) – for standard versions of the various pump types.

## Temperature

Pump type	Temperature in C	Temperature in F
GP	Maximum 150°C	Maximum 300°F
HD/PD/CD*	Maximum 250°C	Maximum 500°F
MD	Maximum 130°C (Magnetic material: Neodymium-Iron-Boron)	Maximum 266°F (Magnetic material: Neodymium-Iron-Boron)
	Maximum 250°C (Magnetic material: Samarium-Cobalt)	Maximum 482°F (Magnetic material: Samarium-Cobalt)
CC	Maximum 80°C	Maximum 175°F

Figure 44: The pump liquid's maximum permitted temperature in C/F for the various pump types. For pumps with a by-pass valve the temperature is limited to a maximum of 150°C/302°F due to the valve key. However, the valve can be supplied with a different key, enabling the pump's temperature range to be fully utilized.

For further temperature restrictions, see the section entitled "Hot liquids".

\*Pump types HD, CD and PD – produced in versions with special tolerances – can in some cases be used up to 300°C/572°F.

MD pumps			
Elastomer type	Elastomer brand	Temperature in C	Temperature in F
FPM	Viton®	Approx. -25°C/+170°C	Approx. -13°F/+338°F
FEP	Teflon® with Viton core	Approx. -60°C/+205°C	Approx. -76°F/+401°F
EPDM	Ethylene-propylene	Approx. -65°C/+120°C	Approx. -85°F/+248°F
FFKM	Kalrez®	Approx. -50°C/+316°C	Approx. -58°F/+601°F

Figure 45: The pump liquid's minimum/maximum temperature limits in C/F for the various elastomers used in a MD pump.

\*Maximum 135°C/ 275°F in water.

## Supplementary requirements for ATEX pumps

1. Dry running not permitted – see section 0. Make sure that there is liquid in the pump casing. Dry running causes heat to develop and the possible creation of sparks by the pump casing, the bearings and by the shaft seals. The formation of bubbles and cavitation in the pump casing are just as dangerous as dry running. You must therefore make sure to bleed the pump if this occurs. Flow and pressure must be monitored and checked regularly.
2. The maximum permitted temperature of the pump surface must be as follows:
  - In the presence of potentially explosive gases, the pump's surface temperature must be equal to or less than 80% of the gas's ignition temperature in Celsius/Fahrenheit
  - In the presence of potentially explosive dust, the temperature must be equal to or less than 2/3 of the ignition temperature in Celsius/Fahrenheit

### Example:

If a pump is surrounded by inflammable gas with an ignition temperature of 100°C/212°F, the pump's surface temperature must be a maximum of 80°C/176°F or less.

3. All instruments and auxiliary systems used in coupling with an ATEX pump, such as gears, motors and flushing systems, must be ATEX-approved components and of the same standard as the pump.
4. Make sure that there is always sufficient lubrication by the slide bearing. Under no circumstances may the slide bearing run out of lubricant. See section 0.
5. The ignition temperature of cooling/heating liquid used must be at least 50 K above the maximum surface temperature of the pump.
6. Blocking the liquid flow by the pressure side is not permitted. Blocking the liquid flow causes rapid pressure increase, and generates heat inside the pump, which is transferred to the pump surface.
7. The pump must be set up and secured firmly to a stable, horizontal base, and it must not be subjected to vibration or external disruption when running.
8. The ball bearing must be replaced after 90% of its service life – see section 17.2.2 Service life – ball bearings.

## Reservations

- The pumps are supplied in accordance with the ATEX Directive and associated standards (EN 1127-1, DS/EN 13463-1 and pr/EN 13463-5).  
DESMI assumes no liability for any personal injury or damage to the pump resulting from any fault, blockage or explosion in the pipe system.  
It is the user's responsibility to protect the pipe system.
- It is the user's responsibility to check for any temperature increase by the pump's surface. See item 0 under "Supplementary requirements for ATEX pumps".
- Observation of regular maintenance is a significant element of the explosion protection process.  
DESMI assumes no liability for any kind of damage/explosion caused by inadequate control, inspection, maintenance or negligence that may lead to the danger of explosion.

## The maintenance process

### The service life of ball bearings

The ball bearings in the bearing bracket (position designation [CU], in 0”Spare parts drawings”) by the free shaft end are all model 63 deep-groove ball bearings, fitted with two rubber seal rings. DESMI fills the bearings with a suitable amount of grease, meaning that any re-lubrication is unnecessary. The same applies for ball bearings located in the rear cover (position designation [BC], in 0”Spare parts drawings”), with the exception of type HD 201, where the ball bearing used is not fitted with seal rings, and re-lubrication is therefore necessary. The service life is halved for every 15°C/59°F increase in temperature over 70°C/158°F. The service life of the ball bearings is further increased to 90% for ATEX pumps – see section 17.2.2 Service life – ball bearings.

### Inspection

#### **During daily inspection, check:**

That the pump is not vibrating or emitting a jarring sound.

That lubricated slide bearings are lubricated, and that there is liquid by the slide bearings lubricated by the liquid.

That any circulation pipes (cooling, heating, pressurized water pipes) are in working order.

That the operating conditions are being observed: pressure, output (amp.), and temperature.

#### **During weekly inspection, check:**

That any filters and drainage holes are clean, and that the areas around the stuffing box and the bearings are free from dust.

#### **During inspection every two months, check:**

That the bearings do not have too much play.

That the oil change intervals for oil-lubricated units are not exceeded.

That the stuffing box is in working order. If necessary, add sealing or reseal (packing rings).

If flexible coupling elements are worn: replace if necessary.

That the by-pass valve, if fitted, is in working order.

#### **During service work, check:**

All parts for wear; worn parts should be replaced.

That all parts in an assembly are positioned correctly.

Pumps supplied with slide bearings for external lubrication must be lubricated as shown in Figure 38. If a pump has been supplied with slide bearings for external lubrication, there is an “M” in the pump designation – see the pump’s name plate.

Example:

HD51BCHD-1M22BS.

During installation, lubricate ROTAN pumps with a Shell grease, Alvania Grease R3. The table below, which shows re-lubrication intervals and amounts of grease, is only a guideline, as re-lubrication intervals in particular are largely dependent on the conditions.

<b>Lubrication of slide bearings</b>					
<b>Pump type:</b> HD, GP, CD, PD, MD, CC	<b>Re-lubrication interval in hours</b>	<b>Amount of grease in grams</b>		<b>Amount of grease in ounce</b>	
		<b>Main bearing (grams)</b>	<b>Idler bearing (grams)</b>	<b>Main bearing (ounce)</b>	<b>Idler bearing (ounce)</b>
<b>26</b>	<b>8 hours</b>	1	1	0.04	0.04
<b>33</b>		1	1	0.04	0.04
<b>41</b>		1	1	0.04	0.04
<b>51</b>		1.5	1.5	0.05	0.05
<b>66</b>		1.5	1.5	0.05	0.05
<b>81</b>		2	2	0.07	0.07
<b>101</b>		2	2.5	0.07	0.09
<b>126</b>		2.5	4	0.09	0.14
<b>151</b>		2.5	6	0.09	0.21
<b>152</b>		4	10	0.14	0.35
<b>201</b>		8	14	0.28	0.49

Figure 46: Re-lubrication intervals and amounts of grease in grams/ounce for lubrication of slide bearings – main bearing and idler bearing.

## The DESMI Group

### **DESMI A/S**

Address: **DESMI A/S**  
Tagholm 1  
9400 Nørresundby  
Denmark

Tel.: +45 96 32 81 11  
Fax: +45 98 17 54 99  
E-mail: [desmi@desmi.com](mailto:desmi@desmi.com)  
Internet: [www.desmi.com](http://www.desmi.com)

---

### **DESMI Inc.**

Address: **DESMI Inc.**  
2551 Eltham Avenue  
Suite G  
Norfolk, Virginia 23513  
USA

Tel.: +1 757 857 7041  
Fax: +1 757 857 6989  
E-mail: [info@desmiusa.com](mailto:info@desmiusa.com)  
Internet: [www.desmiusa.com](http://www.desmiusa.com)

### **DESMI Ltd.**

Address: **DESMI Ltd.**  
"Norman House"  
Rosevale Business Park  
Parkhouse Industrial Estate (West)  
Newcastle, Staffordshire ST5 7UB  
England

Tel.: +44 1782 566900  
Fax: +44 1782 563666  
E-mail: [desmi\\_ltd@desmi.com](mailto:desmi_ltd@desmi.com)  
Internet: [www.desmi.com](http://www.desmi.com)

### **DESMI GmbH Rotan Pumpengesellschaft**

Address: **DESMI GmbH Rotan Pumpengesellschaft**  
Neuhöfer Straße 23  
D-21084 Hamburg  
Germany

Tel.: +49 407 519847  
Fax: +49 407 522040  
E-mail: [desmi\\_gmbh@desmi.com](mailto:desmi_gmbh@desmi.com)  
Internet: [www.desmi.com](http://www.desmi.com)

## DESMI K&R Pompen B.V.

Address: **DESMI K&R Pompen B.V.**  
P.O. Box 9684  
NL-3506 GR Utrecht  
Holland  
Tel.: +31 30 261 00 24  
Fax: +31 30 262 33 14  
E-mail: [desmi\\_kr@desmi.com](mailto:desmi_kr@desmi.com)  
Internet: [www.desmi.com](http://www.desmi.com)

## DESMI Norge AS

Address: **DESMI Norge AS**  
Vigeveien 46  
N-4633 Kristiansand S  
Norway  
Tel.: +47 38 12 21 80  
Fax: +47 38 12 21 81  
E-mail: [desminorge@desmi.com](mailto:desminorge@desmi.com)  
Internet: [www.desmi.com](http://www.desmi.com)



Local distributor:

